

# 3.2 Geometry of 3D Shapes

## Question Paper

Course	DPIB Maths
Section	3. Geometry & Trigonometry
Topic	3.2 Geometry of 3D Shapes
Difficulty	Hard

**Time allowed:** 110  
**Score:** /89  
**Percentage:** /100

**Question 1a**

A trapezoidal prism, ABCDEFGH, is shown in the diagram below. The length of the base is 7.5 cm and the width is 6.3 cm. The height of the prism is 6.5 cm and the length BF is 8.8 cm. In the trapezoidal cross-section ABFE side AB is parallel to side EF.

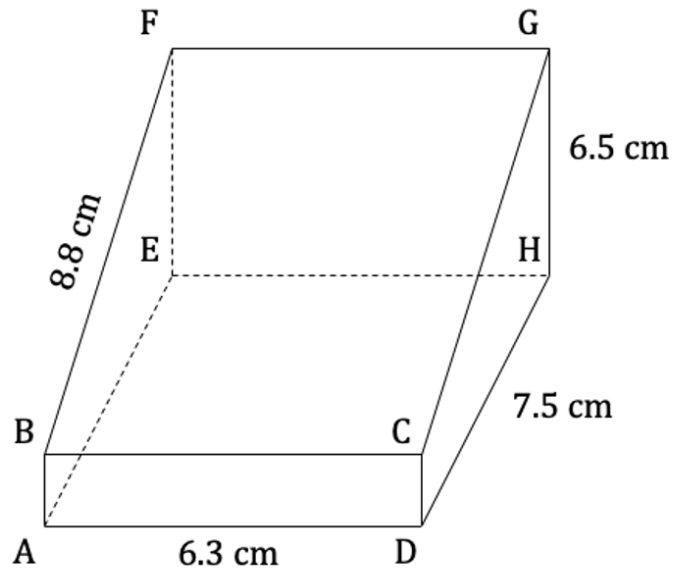

(a) Calculate the length AB.

[3 marks]

**Question 1b**

(b) Find the size of the angle  $\widehat{BHA}$ .

[3 marks]

**Question 2a**

In the diagram below ABCD is the square base of a right pyramid with vertex V. The centre of the base is M. The sides of the square base are 4.2 cm and the vertical height is 10.6 cm.

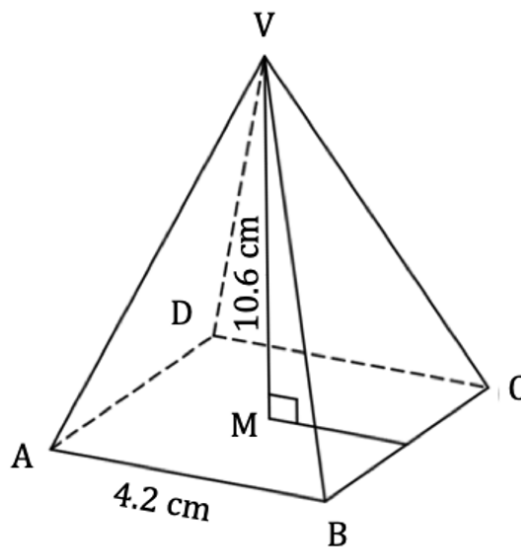

(a) Calculate the area of the triangle ABV.

[3 marks]

**Question 2b**

(b) Calculate the length of AV.

[3 marks]

**Question 2c**

(c) Find the size of the angle  $AV$  makes with the square base  $ABCD$ .

[3 marks]

**Question 3a**

A symmetrical candle with the shape of a right circular cone has a circular base with radius  $r$  cm and an initial height of  $h_1$  cm. As the candle burns the height decreases, but the candle maintains the shape of a right circular cone with the same base radius.

(a) Find an expression, in terms of  $h_1$ , for the height of the remaining unburnt candle,  $h_2$ , when exactly a quarter of the initial volume has been burnt.

[5 marks]

**Question 3b**

The height of the candle is 5cm when a quarter of its volume has been burnt.

(b) Calculate the initial height of the candle.

[3 marks]

Question 4a

ABCDEF is a pencil case in the shape of a triangular prism. The end of the pencil case is an isosceles triangle where  $AC = 4\text{ cm}$  and  $AB = BC = 6\text{ cm}$ . The length of the pencil case is  $11\text{ cm}$ . M is the midpoint of AB. This information is shown in the diagram below.

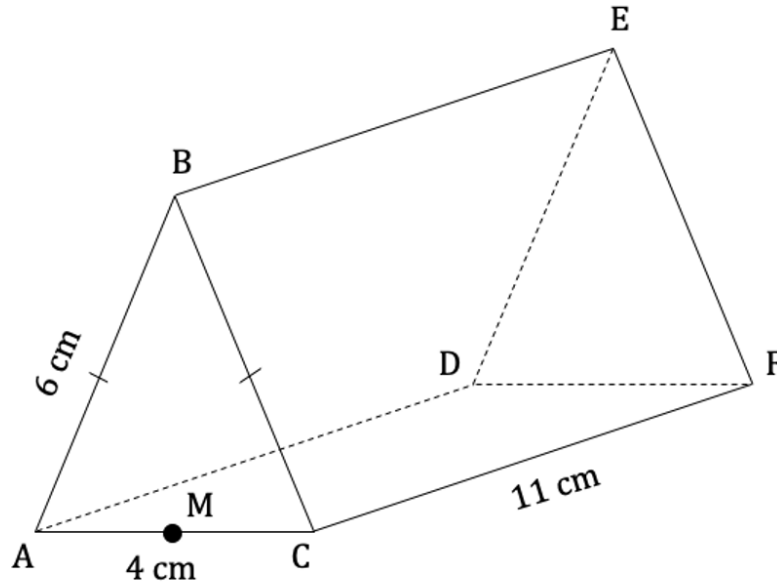

(a) Show that the volume of the pencil case is  $88\sqrt{2}\text{ cm}^3$ .

[4 marks]

Question 4b

(b) Calculate angle  $\widehat{BFM}$ .

[2 marks]

**Question 4c**

(c) Find the length of the longest pencil that could fit into the pencil case.

[2 marks]

**Question 5a**

A coffee scoop is made out of 2 mm thick stainless steel. It is in the shape of a hemisphere and has an outer diameter of 3.8 cm.

(a) Show that the outer surface area of the scoop is  $\frac{361}{50} \pi \text{ cm}^2$ .

[2 marks]

**Question 5b**

(b) Calculate the volume of coffee that the scoop can hold, in  $\text{cm}^3$ .

[3 marks]

**Question 5c**

The density of the coffee when compacted in the scoop is  $0.825 \text{ g/cm}^3$ . A single bag of ground coffee beans contains 350 g and costs \$16.

(c) Calculate the cost per scoop of ground coffee.

[4 marks]



**Question 6a**

Two points, A (2, 1, 3) and B (5, 2, 6), are located on an  $xyz$  coordinate grid as shown in the diagram below.

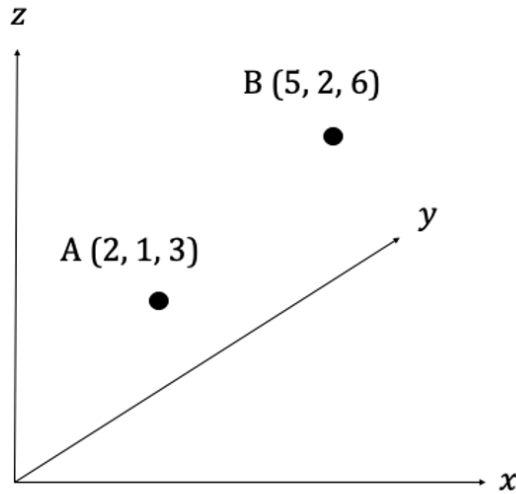

(a) Find the length of AB.

[2 marks]

**Question 6b**

(b) Find the coordinates of the midpoint of [AB].

[2 marks]

**Question 6c**

(c) Calculate the angle between the line (AB) and  $xy$  plane.

[4 marks]

**Question 7a**

A number of model buildings are created in the shape of a rectangular based right pyramid. A single model, ABCDE, has a base of 4.6 cm by 7.2 cm and a slant height of 8.3 cm, as shown in the diagram below.

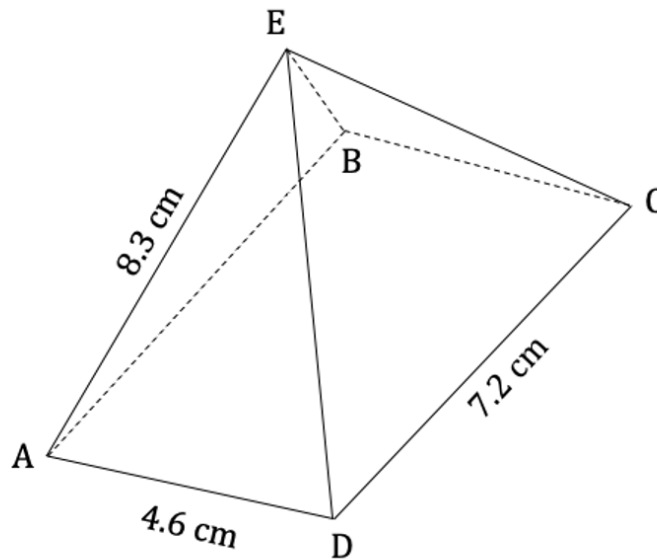

(a) Calculate the volume of one of the models.

[4 marks]

**Question 7b**

The entire surface of the model is to be painted with the exception of the base, which will be glued to the surface on which the models are to be set up. An 18 ml pot of model paint will cover an area of  $120 \text{ cm}^2$ .

(b) Calculate the number of pots of paint that would need to be purchased to paint 8 of these models.

[5 marks]

**Question 8a**

The packaging for a particular firework consists of a thin piece of cardboard in the shape of a right cone with a height of 7.5 cm. The radius of the base is 5.3 cm.

(a) Calculate the area of cardboard required for the packaging.

[3 marks]

**Question 8b**

(b) Calculate the volume of the cone.

[2 marks]

**Question 8c**

The firework company wants to reduce the amount of packaging material used without changing the volume of the cone.

(c) Calculate the radius that the cone needs to be if the height is increased to 7.8 cm. Give your answer to 1 decimal place.

[3 marks]

**Question 8d**

(d) Using your answer from part (c) show that the new cone will require less packaging material than the original cone.

[3 marks]

**Question 9a**

A company manufactures metal doorknobs that consist of a cylinder of radius 27 mm and height 20 mm topped with a solid hemisphere. The cylindrical portion is also solid, save for a cylindrical hole in the base with diameter 4 mm and depth 19 mm to accommodate a screw. The axis of the cylindrical hole is perpendicular to the base of the doorknob. A diagram showing this information can be seen below.

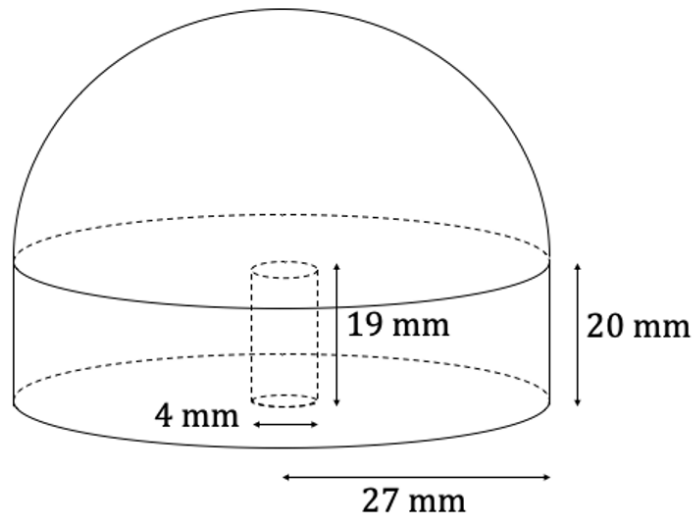

(a) Show that the volume of material required to construct the doorknob is  $27626\pi \text{ mm}^3$ .

[4 marks]

**Question 9b**

The cost of the metal used to make the doorknob has risen to  $\$0.00027/\text{mm}^3$ .

(b) Calculate the amount of money that will be saved per doorknob if the diameter of the doorknob is reduced by 5 mm. Give your answer to 2 decimal places.

[5 marks]

**Question 10a**

A rectangular swimming pool is to be constructed with length 22 m and width 14 m. The depth of the swimming pool is 3.1 m at the deep end rising to 1.2 m at the shallow end as shown in the diagram below. The four vertical sides of the swimming pool are all perpendicular to the horizontal top surface.

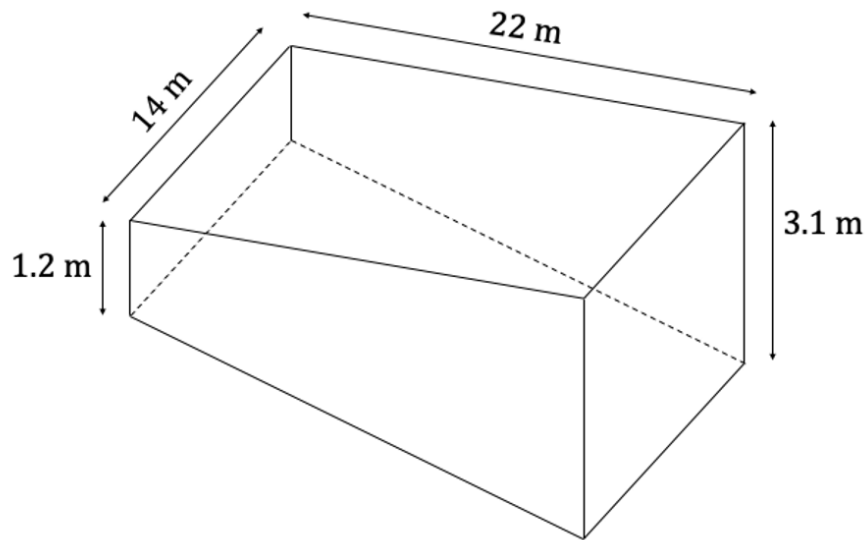

The pool is filled to a height of 14 cm below the top edge of the pool.

(a) Calculate the volume of water in the swimming pool.

[3 marks]

**Question 10b**

A partial draining of the water is required to investigate a problem with one of the walls, so  $\frac{2}{3}$  of the water is temporarily removed.

(b) Find the height of the water that is now in the deepest part of the pool.

[5 marks]

**Question 10c**

(c) Calculate the area of the base of the pool that is left uncovered by water.

[4 marks]



