

# 2.2 Forces

## Question Paper

Course	DPIB Physics
Section	2. Mechanics
Topic	2.2 Forces
Difficulty	Easy

**Time allowed:** 60  
**Score:** /45  
**Percentage:** /100

### Question 1a

The helicopter below is moving horizontally through still air. The lift force from the helicopter's blades is labelled **A**.

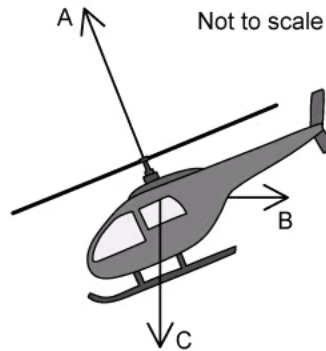

- (a)  
Identify the two forces **B** and **C** that also act on the helicopter.

[2]

[2 marks]

### Question 1b

The force **B** has a value of 25 kN and acts horizontally and at right angles to the weight **C**.

- (b)  
Calculate the horizontal component of force **A** needed to keep the helicopter moving at a constant velocity.

[1]

[1 mark]

### Question 1c

The helicopter encounters a problem and accelerates vertically downwards towards the ground. It has a mass of 50 000 kg. Air resistance is negligible.

- (c)  
Calculate the weight of the helicopter.

[2]

[2 marks]

### Question 1d

(d)

State the name of the law of motion that relates to the equation  $F = ma$ .

[1]

[1 mark]

### Question 2a

The diagram below shows a ball suspended from a cable. The ball is pulled into the position shown by a rope that is kept horizontal.

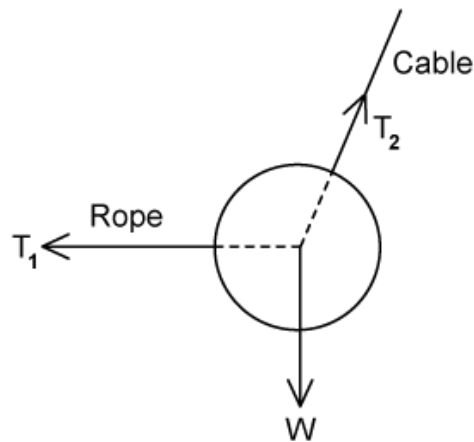

In this position, the ball is in equilibrium.

(a)

State the force and component that balance:

(i)

The force of the rope on the ball

[1]

(ii)

The weight of the ball

[1]

[2 marks]

### Question 2b

The ball is then detached from the rope, so it is hanging only by the cable. The mass of the ball is 350 kg.

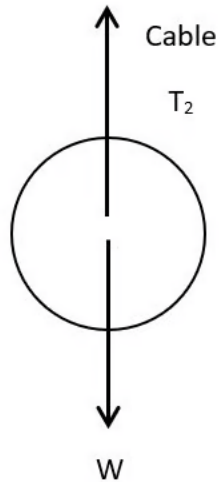

- (b)  
Calculate the new tension in the cable.

[2]

[2 marks]

### Question 2c

The ball is stationary when hanging from the string.

- (c)  
Define translational equilibrium.

[1]

[1 mark]

### Question 2d

The ball remains hanging and does not fall to the ground.

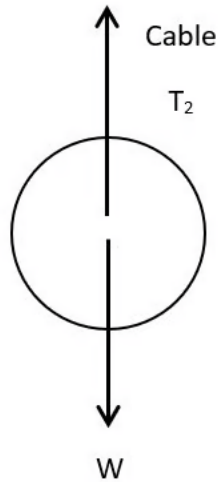

(d)

State, in relation to this situation:

(i)

Newton's first law:

[1]

(ii)

Newton's second law:

[1]

(iii)

The relationship between tension and weight:

[1]

(iv)

The behaviour of the ball if the weight was bigger:

[2]

**[5 marks]**

### Question 3a

The diagram below shows a skier being towed at a constant speed whilst sinking into the snow.

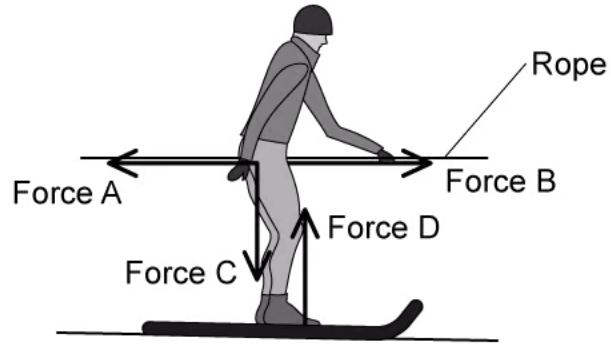

- (a)  
State the name of each of the forces A - D acting on the skier.

[4]

[4 marks]

### Question 3b

(b)

Place a tick (✓) next to the correct statements in the table below:

Force D > Force C	
Force C > Force D	
Force B > Force A	
Force A = Force B	

[2]

[2 marks]

### Question 3c

The skier is pulled off the snow onto an area of grass and becomes stuck.

(c)

State the type of friction present between the bottom of the skis and the grass when she is stationary.

[1]

[1 mark]

### Question 3d

The mass of the skier is 52 kg and the coefficient of friction between the skis and the grass is 0.12.

(d)

Calculate the minimum force needed from the rope to get the skier just on the point of moving again.

[2]

[2 marks]

### Question 4a

A remote-controlled boat has a mass of 6 kg and is accelerating with a resultant force of 1.95 N.

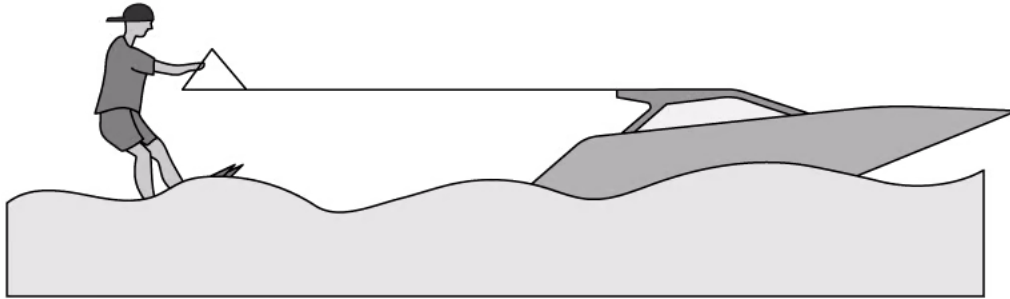

(a)

Draw a free body diagram showing and labelling the forces acting on the boat.

[5]

[5 marks]

### Question 4b

(b)

Calculate the acceleration on the boat.

[3]

[3 marks]



### Question 4c

The boat's velocity changes so that it is travelling at constant speed.

(c)

Place a tick (✓) next to the statement or statements that are correct about the motion of the boat.

The sum of the tension, friction and air resistance is larger than the forward force	
The sum of the tension, friction and air resistance is equal to the forward force	
The upthrust is larger than the weight of the boat	
The upthrust is equal to the weight of the boat	

[2]

[2 marks]

### Question 4d

After 1.8 s the motor is switched off and the boat decelerates uniformly until it stops. The deceleration of the boat is  $0.80 \text{ m s}^{-2}$ .

(d)

The resistive forces, air resistance, tension and friction are the only forces acting on the boat once the motor is switched off. Calculate the magnitude of these forces.

[2]

[2 marks]

### Question 5a

A wooden block is resting on a table as shown.

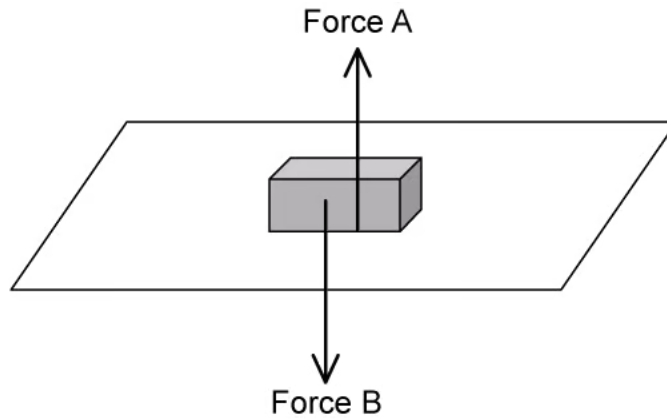

(a)

Name the forces **A** and **B** acting on the block.

[2]

[2 marks]

### Question 5b

A force of 5.8 N is applied to the block to move it along the table at a constant speed.

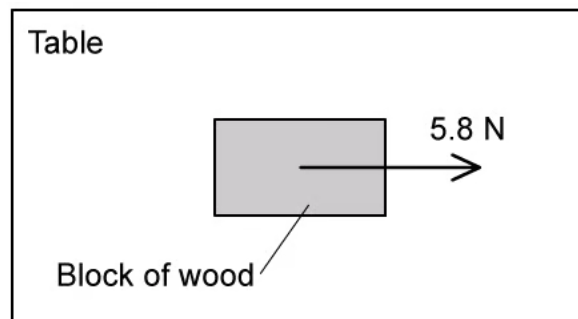

(b)

Identify the type of friction now present between the block and the table.

[1]

[1 mark]

### Question 5c

(c)

State the magnitude of the frictional force on the block.

[1]

[1 mark]

### Question 5d

The block has a mass of 1.5 kg.

(d)

Calculate the magnitude of the dynamic coefficient of friction between the block and the table.

[4]

[4 marks]