

# 3.2 Geometry of 3D Shapes

## Question Paper

Course	DPIB Maths
Section	3. Geometry & Trigonometry
Topic	3.2 Geometry of 3D Shapes
Difficulty	Very Hard

**Time allowed:** 110  
**Score:** /87  
**Percentage:** /100

**Question 1**

Sphere 1 has radius  $r_1$ , volume  $V_1$  and surface area  $A_1$ , and sphere 2 has radius  $r_2$ , volume  $V_2$  and surface area  $A_2$ . Sphere 2 has eight times the mass of sphere 1 and both spheres are made out of the same material. Find the ratio of extra paint needed to paint the surface of sphere 2 compared to that needed to paint the surface of sphere 1.

**[7 marks]**

**Question 2a**

A lunchbox has a rectangular base of length 18 cm and width 12.5 cm. The height of the box at the front, shallower end is 6.4 cm, rising to a height of 9.6 cm at the far end. There is an internal divider that is parallel to the front and the back, situated at a distance of  $x$  cm from the shallower end of the box. All of the sides are perpendicular to the base. A diagram representing this information is given below.

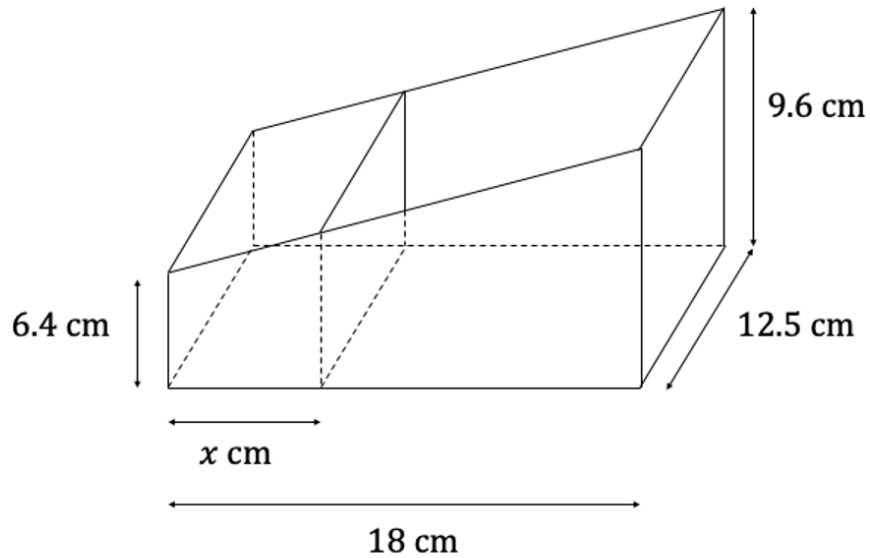

(a) Calculate the total volume of the lunchbox.

[2 marks]

**Question 2b**

(b) Show that the volume of the front, shallower compartment can be expressed as

$$10x \left( \frac{72 + x}{9} \right) \text{ cm}^3$$

[4 marks]

**Question 3a**

A firepit is constructed from a solid cuboid of stone, ABCDEFGH, with a length and width of 62 cm and a height of 42 cm. A depression in the shape of a hemisphere with diameter 48 cm is removed from the centre of the top face of the cuboid. M is the centre of the base of the hole. This information can be seen in the diagram below.

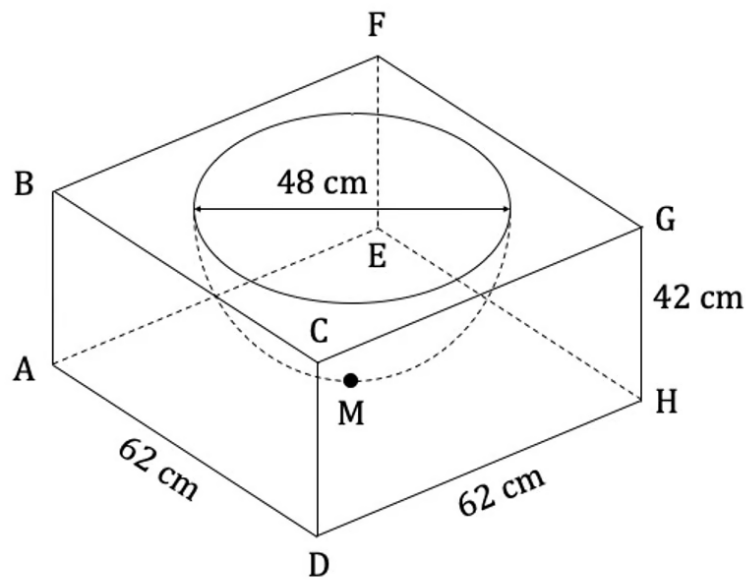

(a) Calculate the distance MA.

[3 marks]

**Question 3b**

The density of the stone is  $1602 \text{ kg/m}^3$ .

(b) Calculate the mass of a single firepit.

[4 marks]

**Question 3c**

The cost of the stone is AUS \$676 per  $\text{m}^3$  and labour costs AUS \$38 per hour. It takes 4 hours to make one firepit. The company constructing the firepits has a budget of AUS \$2000.

(c) Calculate the number of firepits that can be constructed within budget. You need only consider the volume of stone in a completed firepit in your answer.

[4 marks]

**Question 4a**

A building is to be constructed with a concrete slab foundation. In order to accommodate this foundation, a rectangular section of earth measuring 25 m by 28 m is removed to a depth of 1.3 m. The removed earth is used to create a hemispherical landscaped feature in order to reduce waste.

(a) Calculate the diameter of the landscaped hemisphere that can be created.

[4 marks]

**Question 4b**

The architect has decided that a cylindrical area 2 m in height would be more appropriate than a hemisphere as a design feature.

(b) Given that the maximum straight-line distance that is available on the site for landscaping features is 20 m, show that the cylindrical design would not be suitable for the site.

[3 marks]

**Question 5a**

The diagram below shows a product in the shape of a sphere with radius 3.6 cm. The product is packed in cuboidal packing crates measuring 1.7 m by 0.9 m with a depth of 22 cm. The spheres are stacked directly on top of and next to each other, using gum to fix them in position. Each layer contains the same number of spheres.

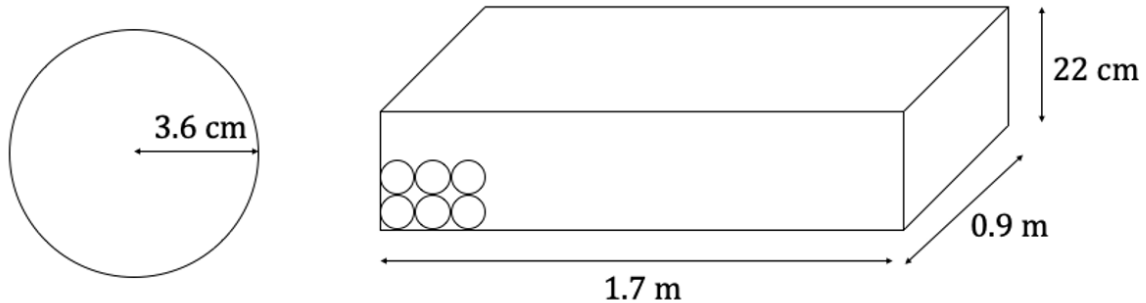

(a) Find the number of spheres that can be packed in a single crate.

[3 marks]

**Question 5b**

(b) Calculate the volume of unused space between the spheres.

[3 marks]

**Question 5c**

The company that has created the product wants to reduce costs by increasing the number of items that they can pack in one crate. They re-design the product in the shape of a cylinder keeping the radius and the volume the same.

(c) Show that, to 3 significant figures, there is a 30.9% decrease in unused space in the packing crate if the cylindrical tube design is used instead of the spherical design.

[5 marks]



**Question 6a**

The diagram below shows a door wedge, ABCDEFGH. ADEH is a horizontal surface and angles  $\widehat{GHD}$  and  $\widehat{FEA}$  are right angles. The face ABCD is a square face parallel to EFGH with the centres of AD and EH being aligned.  $FG = 12$  cm,  $GH = 7$  cm,  $DH = 15$  cm and  $AD = 2$  cm. This information is represented in the diagram below.

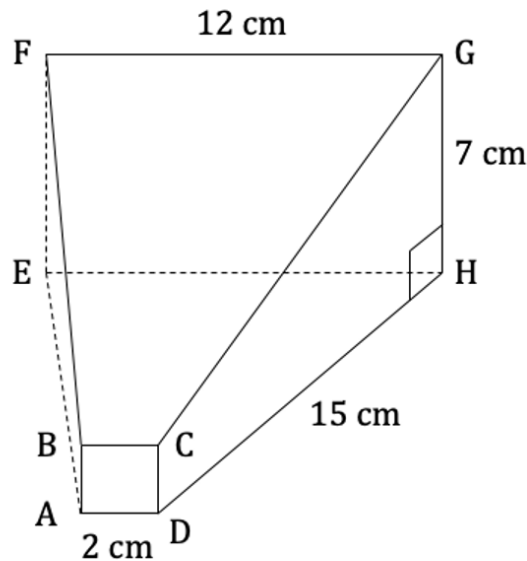

(a) Find the size of the angle  $\widehat{CGH}$ .

[2 marks]

**Question 6b**

(b) Calculate the length AG.

[4 marks]

**Question 6c**

- (c) (i) Find the perpendicular distance between BC and FG.
- (ii) Hence find the angle that the plane BCFG makes with the horizontal.

**[4 marks]**

**Question 7a**

The diagram below shows a frustum, ABCDEFGH, that has been made by removing a square based pyramid of height 4 cm from a solid square based pyramid of height 12 cm and base length 3 cm. Plane EFGH is parallel to plane ABCD.

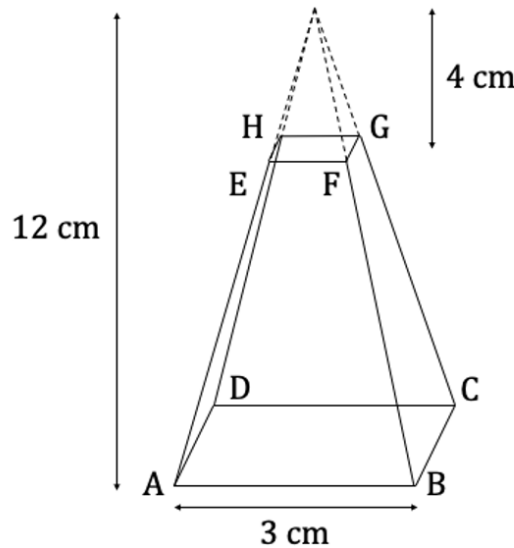

(a) Calculate the volume of the frustum.

[3 marks]

**Question 7b**

(b) Calculate the surface area of the frustum.

[4 marks]

**Question 7c**

(c) Find the length AG.

[5 marks]

**Question 8a**

A cuboid, ABCDEFGH, has sides of length  $2x$  cm,  $2\sqrt{3}x$  cm and  $x$  cm. A diagram representing this information is shown below.

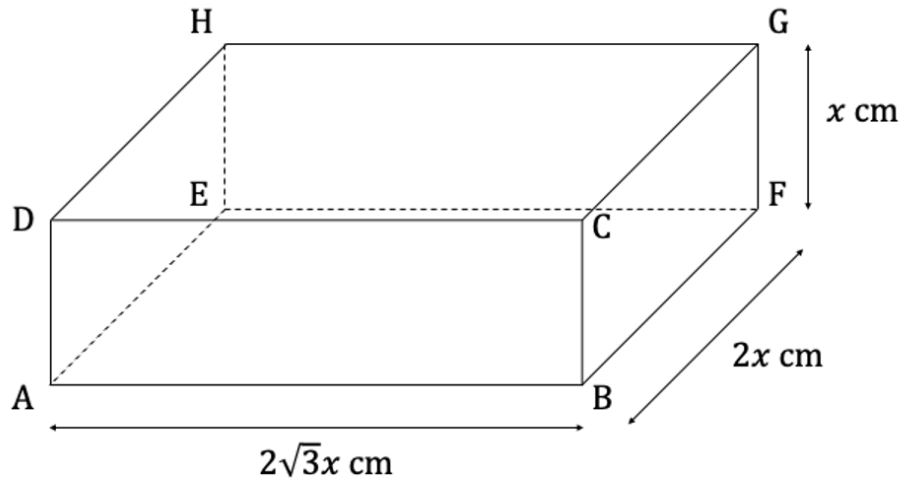

(a) Show that the length BH can be expressed as  $\sqrt{17}x$  cm.

[3 marks]

**Question 8b**

(b) Find an expression that describes the surface area of the cuboid.

[3 marks]

**Question 8c**

M is the midpoint of AF.

(c) Find the angle that the line MG makes with the horizontal plane.

[3 marks]

**Question 9**

An ice cream cone is in the form of a right cone with a slant height of 9.1 cm and a perpendicular height of 8.7 cm. The bottom of the ice cream cone is filled with chocolate. The top of the chocolate layer is a circle of diameter 1 cm parallel to the circle forming the open top of the cone. A diagram representing this information can be seen below.

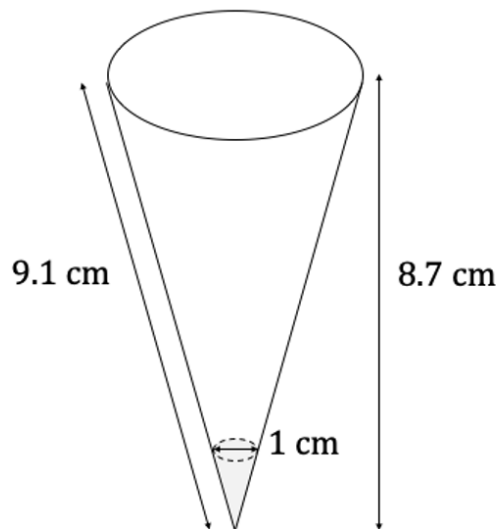

A sphere of ice cream, with radius  $r$ , is placed on top of the cone. It can be assumed that when the ice cream melts it will run into the cone and not down the sides until the cone is full and overflows.

Find the radius  $r$  that the sphere of ice cream must have in order for it to fill the space inside the cone perfectly when melted, leaving no empty space and not overflowing.

[6 marks]

**Question 10a**

A spherical ball bearing of radius 4 mm is fired onto a vertical surface made of soft clay and is embedded to a depth of 2.3 mm. The shape of the ball bearing is not distorted by the impact.

A spherical cap is a portion of a sphere cut off with a plane, as can be seen in the diagram below.

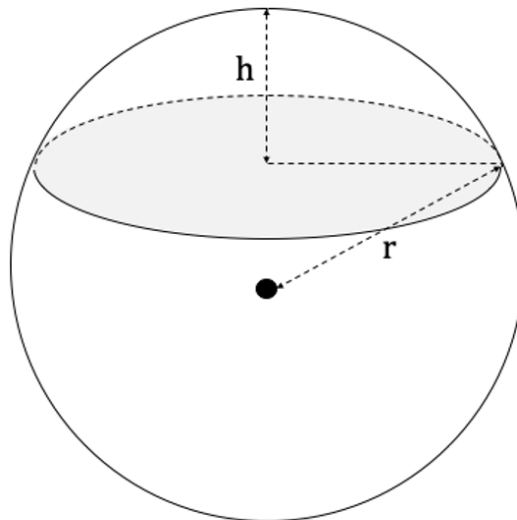

The volume of a spherical cap can be calculated using the following formula:  $V = \frac{1}{3}\pi h^2(3r - h)$  where  $r$  is the radius of the sphere and  $h$  is the height of the spherical cap.

(a) Calculate the volume of soft clay that is displaced by the ball bearing.

[2 marks]



**Question 10b**

(b) Find the angle between the plane forming the cap and the radius connecting the centre of the sphere to the point where the plane intersects the surface of the sphere.

[2 marks]

**Question 10c**

A second ball bearing is fired at the soft clay surface and is embedded to a depth of 2.8 mm. The volume of soft clay that is displaced is the same as it is in part (a).

(c) Find the surface area of the second ball bearing.

[4 marks]