

IB Physics DP

YOUR NOTES



1. Measurement & Uncertainties

CONTENTS

- 1.1 Measurements in Physics
 - 1.1.1 SI Units
 - 1.1.2 Using Scientific Notation
 - 1.1.3 Estimating Physical Quantities
- 1.2 Uncertainties & Errors
 - 1.2.1 Random & Systematic Errors
 - 1.2.2 Calculating Uncertainties
 - 1.2.3 Determining Uncertainties from Graphs
- 1.3 Vectors & Scalars
 - 1.3.1 Vector & Scalar Quantities
 - 1.3.2 Combining & Resolving Vectors
 - 1.3.3 Solving Vector Problems

1.1 Measurements in Physics

1.1.1 SI Units

YOUR NOTES



SI Base Quantities

International System (S.I.) Units

- There is a seemingly endless number of units in Physics
- These can all be reduced to seven base units from which every other unit can be derived
- These seven units are referred to as the SI Base Units; making up the system of measurement officially used in almost every country around the world

SI Base Quantities Table

QUANTITY	SI BASE UNIT	SYMBOL
MASS	KILOGRAM	kg
LENGTH	METRE	m
TIME	SECOND	s
CURRENT	AMPERE	A
TEMPERATURE	KELVIN	K
AMOUNT OF SUBSTANCE	MOLE	mol

Copyright © Save My Exams. All Rights Reserved

Six SI quantities are shown. The seventh quantity, the candela, measures luminous intensity, and is not covered in IB Physics. You may meet it later if you continue with Physics at university.

Derived Units

Derived Units

- Derived units are derived from the seven SI Base units
- The base units of physical quantities such as:
 - Newtons, **N**
 - Joules, **J**
 - Pascals, **Pa**, can be deduced
- To deduce the base units, it is necessary to use the definition of the quantity
- The Newton (N), the unit of force, is defined by the equation:
 - Force = mass \times acceleration
 - $N = \text{kg} \times \text{m s}^{-2} = \text{kg m s}^{-2}$
 - Therefore, the Newton (N) in SI base units is **kg m s⁻²**
- The Joule (J), the unit of energy, is defined by the equation:
 - Energy = $\frac{1}{2} \times \text{mass} \times \text{velocity}^2$
 - $J = \text{kg} \times (\text{m s}^{-1})^2 = \text{kg m}^2 \text{s}^{-2}$
 - Therefore, the Joule (J) in SI base units is **kg m² s⁻²**
- The Pascal (Pa), the unit of pressure, is defined by the equation:
 - Pressure = force \div area
 - $\text{Pa} = \text{N} \div \text{m}^2 = (\text{kg m s}^{-2}) \div \text{m}^2 = \text{kg m}^{-1} \text{s}^{-2}$
 - Therefore, the Pascal (Pa) in SI base units is **kg m⁻¹ s⁻²**

YOUR NOTES



1.1.2 Using Scientific Notation

YOUR NOTES



Scientific Notation & Metric Multipliers

Scientific Notation

- In physics, **measured quantities** cover a large range from the very large to the very small
- Scientific notation is a form that is based on powers of 10
- The scientific form must have **one digit** in front of the decimal place
 - Any remaining digits remain behind the decimal place
 - The magnitude of the value comes from multiplying by 10^n where n is called 'the power'
 - This power is positive when representing large numbers or negative when representing small numbers



Worked Example

Express 4 600 000 in scientific notation.

Step 1: Write the convention for scientific notation

- To convert into scientific notation, only one digit may remain in front of the decimal point
 - Therefore, the scientific notation must be 4.6×10^n
- The value of n is determined by the number of decimal places that must be moved to return to the original number (i.e. 4 600 000)

Step 2: Identify the number of digits after the 4

- In this case, that number is +6

Step 3: Write the final answer in scientific notation

- The solution is: 4.6×10^6

Metric Multipliers

- When dealing with magnitudes of 10, there are **metric names** for many common quantities
- These are known as metric multipliers and they change the **size** of the **quantity** they are applied to
 - They are represented by prefixes that go in front of the measurement
- Some common examples that are well-known include
 - **kilometres, km** ($\times 10^3$)
 - **centimetres, cm** ($\times 10^{-2}$)
 - **milligrams, mg** ($\times 10^{-3}$)
- Metric multipliers are represented by a single letter symbol such as centi- (c) or Giga- (G)
 - These letters go in front of the quantity of interest
 - For example, centimetres (cm) or Gigawatts (GW)

Common Metric Multipliers Table

PREFIX	ABBREVIATION	POWER OF TEN
TERA-	T	10^{12}
GIGA-	G	10^9
MEGA-	M	10^6
KILO-	k	10^3
CENTI-	c	10^{-2}
MILLI-	m	10^{-3}
MICRO-	μ	10^{-6}
NANO-	n	10^{-9}
PICO-	p	10^{-12}

YOUR NOTES



Worked Example

What is the answer to the addition of $3.6 \text{ Mm} + 2700 \text{ km}$ in metres?

Step 1: Check which metric multipliers are in this problem

- o M represents **Mega-** which is $\times 10^6$ (not milli- which is small m!)
- o k represents **kilo-** which is a multiplier of $\times 10^3$

Step 2: Apply these multipliers to get both quantities to be metres

$$3.6 \times 10^6 \text{ m} + 2.7 \times 10^6 \text{ m}$$

Step 3: Write the final answer in units of metres

$$6.3 \times 10^6 \text{ m}$$



Exam Tip

You are expected to know metric multipliers for your exams. Make sure you become familiar with them in order to avoid any mistakes.

Significant Figures

- Significant figures are the digits that accurately represent a given quantity
- Significant figures describe the precision with which a quantity is known
 - If a quantity has **more significant figures** then **more precise** information is known about that quantity

Rules for Significant Figures

- Not all digits that a number may show are significant
- In order to know how many digits in a quantity are significant, these rules can be followed
 - **Rule 1:** In an integer, all digits count as significant if the last digit is non-zero
 - **Example:** 702 has 3 significant figures
 - **Rule 2:** Zeros at the end of an integer do not count as significant
 - **Example:** 705,000 has 3 significant figures
 - **Rule 3:** Zeros in front of an integer do not count as significant
 - **Example:** 0.002309 has 4 significant figures
 - **Rule 4:** Zeros at the end of a number less than zero count as significant, but those in front do not.
 - **Example:** 0.0020300 has 5 significant figures
 - **Rule 5:** Zeros after a decimal point are also significant figures.
 - **Example:** 70.0 has 3 significant figures
- Combinations of numbers must always be to the smallest number significant figures



Worked Example

What is the solution to this problem to the correct number of significant figures: 18×384 ?

Step 1: Identify the smallest number of significant figures

- 18 has only 2 significant figures, while 384 has 3 significant figures
- Therefore, the final answer should be to 2 significant figures

Step 2: Do the calculation with the maximum number of digits

$$18 \times 384 = 6912$$

Step 3: Round to the final answer to 2 significant figures

$$6.9 \times 10^3$$

YOUR NOTES



Estimating Physical Quantities

YOUR NOTES



- To estimate is to obtain an approximate value
 - For **very** large or small quantities, using **orders of magnitudes** to estimate calculations is a valid approach
- Estimation is typically done to the nearest order of magnitude

? Worked Example

Estimate the order of magnitude of the following:

- a) The temperature of an oven (in Kelvin)
- b) The volume of the Earth (in m^3)
- c) The number of seconds in a person's life if they live to be 95 years old

Part (a)

The temperature of the oven:

Step 1: Identify the approximate temperature of an oven

- A conventional oven works at $\sim 200^\circ\text{C}$ which is 473 K

Step 2: Identify the order of magnitude

- Since this could be written as $4.73 \times 10^2 \text{ K}$
- The order of magnitude is $\sim 10^2$

Part (b)

The volume of the Earth (in m^3):

Step 1: Identify the approximate radius of the Earth

- The radius of the Earth is $\sim 6.4 \times 10^6 \text{ m}$

Step 2: Use the radius to calculate the volume

- The volume of a sphere is equal to:

$$V = \frac{4}{3} \pi r^3$$

$$V = \frac{4}{3} \times \pi \times (6.4 \times 10^6)^3$$

$$V = 1.1 \times 10^{21} \text{ m}^3$$

Step 3: Identify the order of magnitude

- The order of magnitude is $\sim 10^{21}$

Part (c)

The number of seconds in 95 years:

Step 1: Find the number of seconds in a single year

1 year = 365 days with 24 hours each with 60 minutes with 60 seconds

$$365 \times 24 \times 60 \times 60 = 31\,536\,000 \text{ seconds in a year}$$

Step 2: Find the number of seconds in 95 years

$$95 \times 31\,536\,000 = 2\,838\,240\,000 \text{ seconds}$$

- This is approximately 2.84×10^8 seconds
- Therefore the order of magnitude is $\sim 10^8$



Exam Tip

When studying IB DP Physics, it is recommended to state your answer on a single line explicitly (if possible) with all necessary details to ensure the examiners can mark correctly and for best practice.

YOUR NOTES



1.2 Uncertainties & Errors

1.2.1 Random & Systematic Errors

Random & Systematic Errors

- Measurements of quantities are made with the aim of finding the true value of that quantity
 - In reality, it is impossible to obtain the true value of any quantity as there will always be a degree of **uncertainty**
- The uncertainty is an estimate of the difference between a **measurement reading** and the **true value**
- The two types of **measurement errors** that lead to uncertainty are:
 - Random errors
 - Systematic errors

Random Errors

- Random errors cause unpredictable fluctuations in an instrument's readings as a result of uncontrollable factors, such as environmental conditions
- This affects the precision of the measurements taken, causing a wider spread of results about the mean value
- To **reduce** random error:
 - **Repeat** measurements several times and calculate an average from them

Systematic Errors

- Systematic errors arise from the use of faulty instruments used or from flaws in the experimental method
- This type of error is repeated consistently every time the instrument is used or the method is followed, which affects the accuracy of all readings obtained
- To **reduce** systematic errors:
 - Instruments should be **recalibrated**, or different instruments should be used
 - Corrections or adjustments should be made to the technique

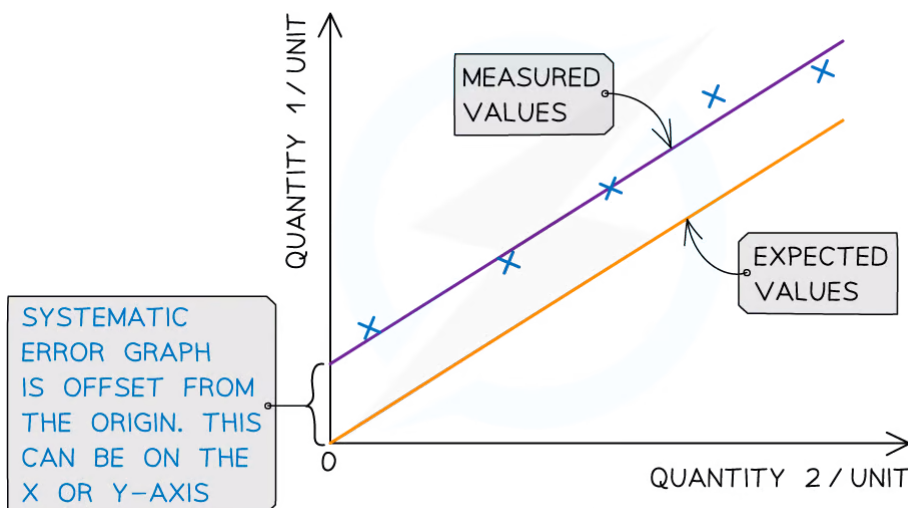

Systematic errors on graphs are shown by the offset of the line from the origin

YOUR NOTES



Zero Errors

- This is a type of systematic error which occurs when an instrument gives a reading when the **true reading is zero**
 - For example, a top-ban balance that starts at 2 g instead of 0 g
- To **account for** zero errors
 - Take the **difference** of the **offset** from each value
 - For example, if a scale starts at 2 g instead of 0 g, a measurement of 50 g would actually be $50 - 2 = 48$ g
 - The offset could be positive or negative

Reading Errors

- When measuring a quantity using an **analogue** device such as a ruler, the uncertainty in that measured quantity is **± 0.5 the smallest measuring interval**
- When measuring a quantity using a **digital** device such as a digital scale or stopwatch, the uncertainty in that measured quantity is **± 1 the smallest measuring interval**
- To **reduce** reading errors:
 - Use a **more precise** device with **smaller measuring intervals** and therefore less uncertainty

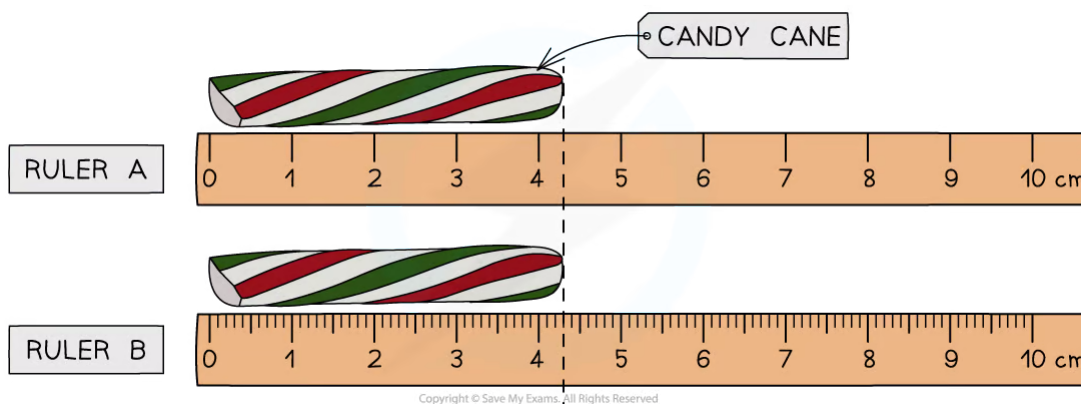

Both rulers measure the same candy cane, yet Ruler B is more precise than Ruler A due to smaller interval size

1.2.2 Calculating Uncertainties

YOUR NOTES



Uncertainties

Precision

- Precise measurements are ones in which there is **very little spread** about the **mean** value, in other words, **how close** the measured values are **to each other**
- If a measurement is repeated several times, it can be described as **precise** when the values are **very similar to, or the same** as, each other
 - Another way to describe this concept is if the **random uncertainty** of a measurement is **small**, then that measurement can be said to be **precise**
- The precision of a measurement is reflected in the values recorded – measurements to a greater number of decimal places are said to be more **precise** than those to a whole number

Accuracy

- A measurement is considered **accurate** if it is close to the true value
 - Another way to describe this concept is if the **systematic error** of a measurement is **small**, then that measurement can be said to be **accurate**
- The accuracy can be **increased by repeating measurements** and finding a mean of the results
- Repeating measurements also helps to identify anomalies that can be omitted from the final results

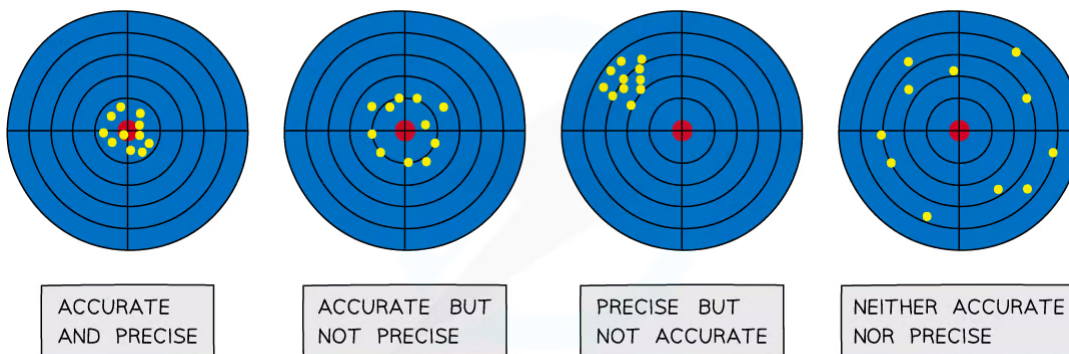

Copyright © Save My Exams. All Rights Reserved

The difference between precise and accurate results

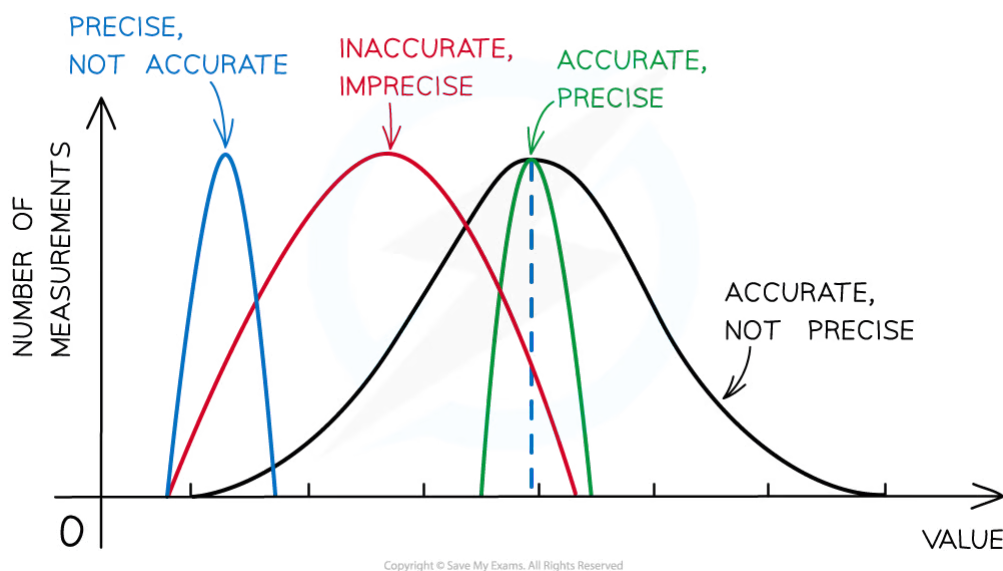

Representing precision and accuracy on a graph

Types of Uncertainty

- There is always a degree of uncertainty when measurements are taken; the uncertainty can be thought of as the difference between the **actual** reading taken (caused by the equipment or techniques used) and the true value
- Uncertainties are **not** the same as errors
 - Errors can be thought of as issues with equipment or methodology that cause a reading to be different from the true value
 - The uncertainty is a range of values around a measurement within which the true value is expected to lie, and is an **estimate**
- For example, if the true value of the mass of a box is 950 g, but a systematic error with a balance gives an actual reading of 952 g, the uncertainty is ± 2 g
- These uncertainties can be represented in a number of ways:
 - **Absolute Uncertainty:** where uncertainty is given as a fixed quantity
 - **Fractional Uncertainty:** where uncertainty is given as a fraction of the measurement
 - **Percentage Uncertainty:** where uncertainty is given as a percentage of the measurement

$$\text{percentage uncertainty} = \frac{\text{uncertainty}}{\text{measured value}} \times 100\%$$

- To find uncertainties in different situations:
 - **The uncertainty in a reading:** \pm half the smallest division
 - **The uncertainty in repeated data:** half the range i.e. $\pm \frac{1}{2}$ (largest - smallest value)
 - **The uncertainty in digital readings:** \pm the last significant digit unless otherwise quoted

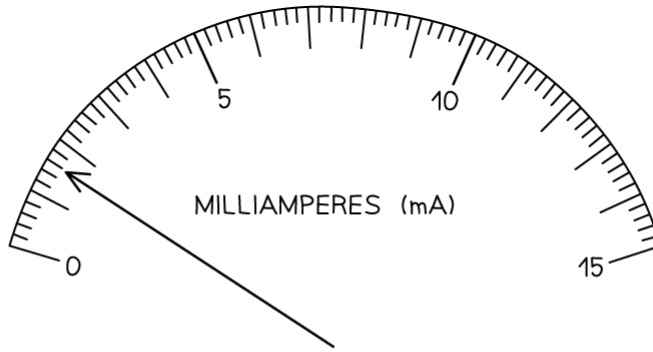

SMALLEST DIVISION = 0.2 mA

READING (I) = 1.6 mA

$$\text{ABSOLUTE UNCERTAINTY } (\Delta I) = \frac{1}{2} \times 0.2 \text{ mA} = 0.1 \text{ mA}$$

$$I = 1.6 \pm 0.1 \text{ mA}$$

$$\text{FRACTIONAL UNCERTAINTY} = \frac{\text{UNCERTAINTY}}{\text{VALUE}} = \frac{0.1}{1.6} = \frac{1}{16}$$

$$I = 1.6 \pm \frac{1}{16} \text{ mA}$$

$$\text{PERCENTAGE UNCERTAINTY } (\%) = \frac{\text{UNCERTAINTY}}{\text{VALUE}} \times 100 = \frac{0.1}{1.6} \times 100 = 6.2\%$$

$$I = 1.6 \pm 6.2\% \text{ mA}$$

Copyright © Save My Exams. All Rights Reserved

How to calculate absolute, fractional and percentage uncertainty

- Always make sure your absolute or percentage uncertainty is to the same number of **significant figures** as the reading

Propagating Uncertainties

YOUR NOTES



Combining Uncertainties

- When combining uncertainties, the rules are as follows:

Adding / Subtracting Data

- Add** together the absolute uncertainties

ADDING / SUBTRACTING DATA

DIAMETER OF TYRE (d_1) = 55.0 ± 0.5 cm



DIAMETER OF INNER TYRE (d_2) = 21.0 ± 0.7 cm

DIFFERENCE IN DIAMETERS ($d_1 - d_2$) = $55.0 - 21.0 = 34.0$ cm

UNCERTAINTY IN DIFFERENCE = $\pm(0.5 + 0.7) = \pm 1.2$ cm

$d_1 - d_2 = 34.0 \pm 1.2$ cm

Multiplying / Dividing Data

- Add** the percentage or fractional uncertainties

MULTIPLYING / DIVIDING DATA



DISTANCE = 50.0 ± 0.1 m

TIME = 5.00 ± 0.05 s

SPEED (v) = $\frac{\text{DISTANCE (s)}}{\text{TIME (t)}}$

$v = \frac{50.0}{5.0} = 10.0 \text{ ms}^{-1}$

$\frac{\Delta v}{v} = \frac{\Delta s}{s} + \frac{\Delta t}{t} = \frac{0.1}{50.0} + \frac{0.05}{5.00} = 0.002 + 0.01 = 0.012$

ABSOLUTE UNCERTAINTY (Δv) = $10.0 \times 0.012 = \pm 0.12 \text{ ms}^{-1}$

$v = 10.0 \pm 0.12 \text{ ms}^{-1}$

Copyright © Save My Exams. All Rights Reserved

Raising to a Power

- Multiply** the percentage uncertainty by the power

RAISING TO A POWER

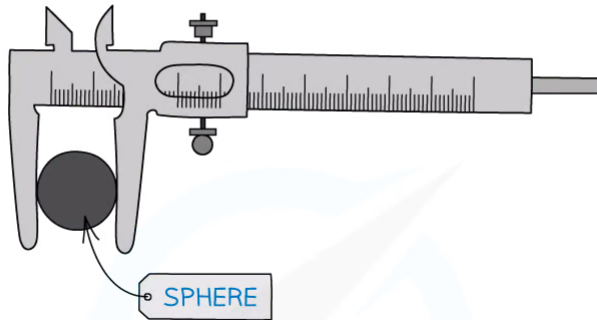

$$V = \frac{4}{3} \pi r^3$$

$$r = 2.50 \pm 0.02 \text{ cm}$$

$$V = \frac{4}{3} \pi (2.50)^3 = 65.5 \text{ cm}^3$$

$$\frac{\Delta V}{V} = 3 \times \frac{\Delta r}{r} = 3 \times \frac{0.02}{2.50} = 0.024$$

ABSOLUTELY UNCERTAINTY (ΔV) = $65.5 \times 0.024 = 1.57 \text{ cm}^3$

PERCENTAGE UNCERTAINTY ($\% \Delta V$) = $100 \times 0.024 = 2.4\%$

Copyright © Save My Exams. All Rights Reserved

? Worked Example

Consider two lengths:

$$A = 5.0 \pm 0.1 \text{ cm and } B = 2.5 \pm 0.1 \text{ cm}$$

Which of the following has the smallest percentage uncertainty

- A. $A + B$
- B. $A - B$
- C. $A \times B$
- D. A

Step 1: List the known quantities

- $A = 5.0 \text{ cm}$
- Uncertainty in A , $\Delta A = 0.1 \text{ cm}$

YOUR NOTES



- $B = 2.5 \text{ cm}$
- Uncertainty in B , $\Delta B = 0.1 \text{ cm}$

YOUR NOTES

**Step 2: Check the percentage uncertainty of option A**

$$A + B = 5.0 + 2.5 = 7.5 \text{ cm}$$

- The rule for propagating uncertainties for adding data ($A + B$) is $\Delta A + \Delta B$
- The combined uncertainties are:

$$0.1 + 0.1 = \pm 0.2 \text{ cm}$$

- Therefore, the percentage uncertainty is:

$$(0.2 \div 7.5) \times 100 \approx 2.7\%$$

Step 3: Check the percentage uncertainty of option B

$$A - B = 5.0 - 2.5 = 2.5 \text{ cm}$$

- The rule for propagating uncertainties for subtracting data ($A - B$) is $\Delta A + \Delta B$
- The combined uncertainties are:

$$0.1 + 0.1 = \pm 0.2 \text{ cm}$$

- Therefore the percentage uncertainty is:

$$(0.2 \div 2.5) \times 100 = 8\%$$

Step 4: Check the percentage uncertainty of option C

$$A \times B = 5.0 \times 2.5 = 12.5 \text{ cm}$$

- The rule for propagating uncertainties for multiplying data ($A \times B$) is $\Delta A/A + \Delta B/B$
- The combined uncertainties are:

$$(0.1 \div 5.0) + (0.1 \div 2.5) = 0.02 + 0.04 = 0.06$$

- Therefore the percentage uncertainty is:

$$0.06 \times 100 = 6\%$$

Step 5: Check the percentage uncertainty of option D

- $A = 5.0 \text{ cm}$ and the uncertainty is 0.1 cm
- Therefore the percentage uncertainty is:

$$(0.1 \div 5.0) \times 100 = 2\%$$

Step 6: Compare and select the answer with the smallest percentage uncertainty

- Comparing the four options, option **D** is the correct answer as it has a value of 2% which is the smallest percentage uncertainty



Worked Example

For the value $B = 3.0 \pm 0.1$, if B is square rooted (\sqrt{B}) what is the answer along with the absolute uncertainty?

Step 1: Find what the value of the quantity will be

$$\sqrt{B} = \sqrt{3.0} \approx 1.73$$

Step 2: Find the percentage uncertainty of the original

$$(0.1 \div 3.0) \times 100 \approx 3.33\%$$

Step 3: The percentage uncertainty needs to be multiplied by the power of the operation

$$3.33 \times (1 \div 2) \approx 1.67\%$$

Step 4: Apply the percentage uncertainty to the absolute answer

1.67% in decimal form is 0.0167. Therefore: $0.0167 \times 1.73 \approx 0.03$

Step 5: State the complete answer

$$\sqrt{B} = 1.73 \pm 0.03$$



Exam Tip

Remember:

- Absolute uncertainties (denoted by Δ) have the same units as the quantity
- Percentage uncertainties have no units
- The uncertainty in constants, such as π , is taken to be zero

YOUR NOTES



1.2.3 Determining Uncertainties from Graphs

YOUR NOTES



Error Bars

- The uncertainty in a measurement can be shown on a graph as an **error bar**
- This bar is drawn above and below the point (or from side to side) and shows the **uncertainty** in that measurement
- Error bars are plotted on graphs to show the **absolute uncertainty** of values plotted

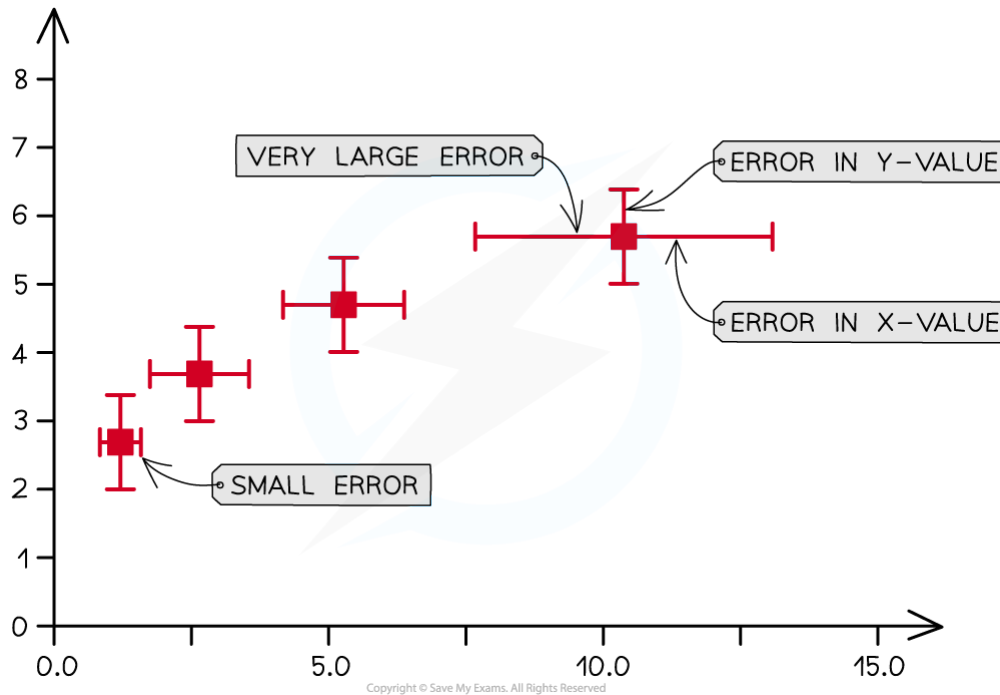

Representing error bars on a graph



Exam Tip

A common misconception is that error bars need to all be the same size. In physics, this is not the case and each data point can have different error bar sizes as they have different uncertainties.

Determining Uncertainties from Graphs

YOUR NOTES



- To calculate the **uncertainty in a gradient**, two lines of best fit should be drawn on the graph:
 - The 'best' line of best fit, which passes as **close to the points as possible**
 - The 'worst' line of best fit, either the **steepest possible** or the **shallowest possible** line which fits within all the error bars

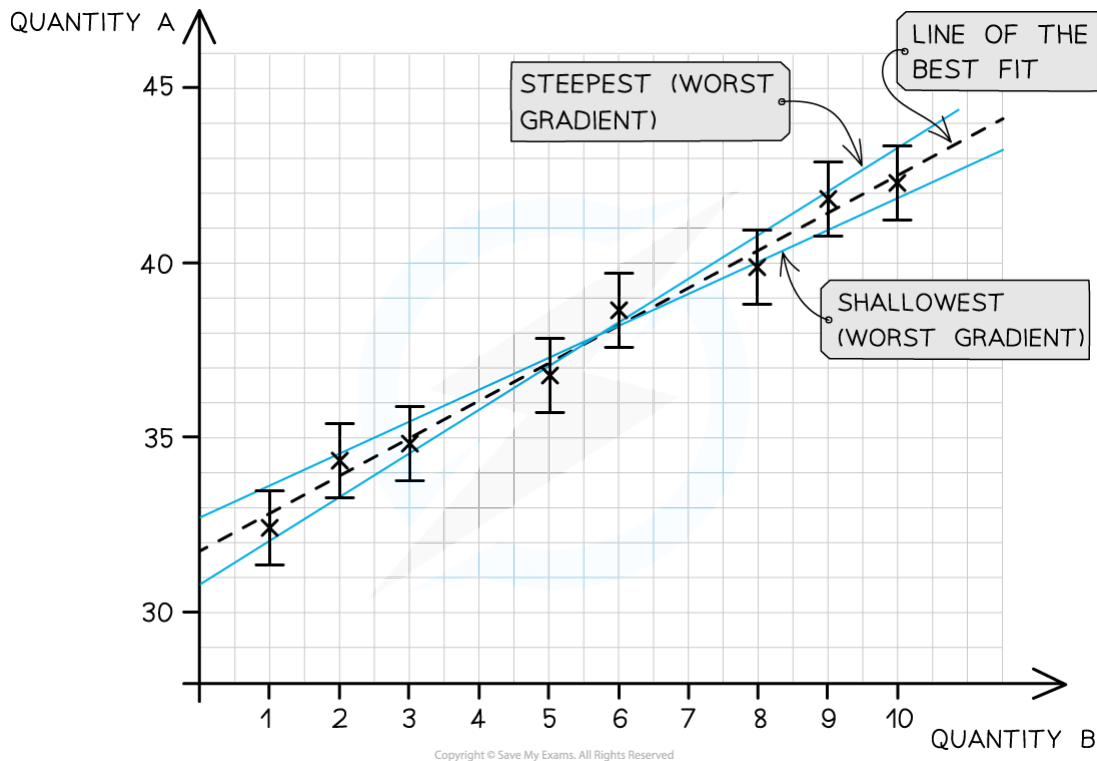

The line of best fit passes as close as possible to all the points. The steepest and shallowest lines are known as the worst fit

- The percentage uncertainty in the **gradient** can be found using the magnitude of the 'best' and 'worst' gradients:

$$\text{percentage uncertainty} = \frac{\text{best gradient} - \text{worst gradient}}{\text{best gradient}} \times 100\%$$

- Either the steepest or shallowest line of best fit may have the 'worst' gradient on a case-by-case basis.
 - The 'worst' gradient will be the one with the **greatest difference** in magnitude from the 'best' line of best fit.
 - The equation **above** is for the case where the 'worst' gradient is the **shallowest**.
 - If the 'worst' gradient is the **steepest**, then the 'worst' gradient should be **subtracted** from the 'best' gradient and **then** divided by the best gradient and multiplied by 100
- Alternatively, the **average** of the two maximum and minimum lines can be used to calculate the percentage uncertainty:

$$\text{percentage uncertainty} = \frac{\text{max. gradient} - \text{min. gradient}}{2} \times 100\%$$

- The percentage uncertainty in the **y-intercept** can be found using:

$$\text{percentage uncertainty} = \frac{\text{best y intercept} - \text{worst y intercept}}{\text{best y intercept}} \times 100\%$$

$$\text{percentage uncertainty} = \frac{\text{max. y intercept} - \text{min. y intercept}}{2} \times 100\%$$

Percentage Difference

- The percentage difference gives an indication of how close the **experimental value** achieved from an experiment is to the **accepted value**
 - It is **not** a percentage uncertainty
- The percentage difference is defined by the equation:

$$\text{percentage difference} = \frac{\text{experimental value} - \text{accepted value}}{\text{accepted value}} \times 100\%$$

- The experimental value is sometimes referred to as the 'measured' value
- The accepted value is sometimes referred to as the 'true' value
 - This may be labelled on a component such as the capacitance of a capacitor or the resistance of a resistor
 - Or, from a reputable source such as a peer-reviewed data booklet
- For example, the acceleration due to gravity g is known to be 9.81 m s^{-2} . This is its **accepted value**
 - From an experiment, the value of g may be found to be 10.35 m s^{-2}
 - Its **percentage difference** would therefore be 5.5 %
- The **smaller** the percentage difference, the more **accurate** the results of the experiment

YOUR NOTES





Worked Example

On the axes provided, plot the graph for the following data and draw error bars and lines of best and worst fit.

Force / N	10	20	30	40	50	60	70	80
Extension / mm	8.5 ± 1	11 ± 0.5	15 ± 1	15 ± 2	20 ± 1.5	19.5 ± 2	22 ± 0.5	26 ± 1

Copyright © Save My Exams. All Rights Reserved

Find the percentage uncertainty in the gradient from your graph.



Step 1: Draw sensible scales on the axes and plot the data

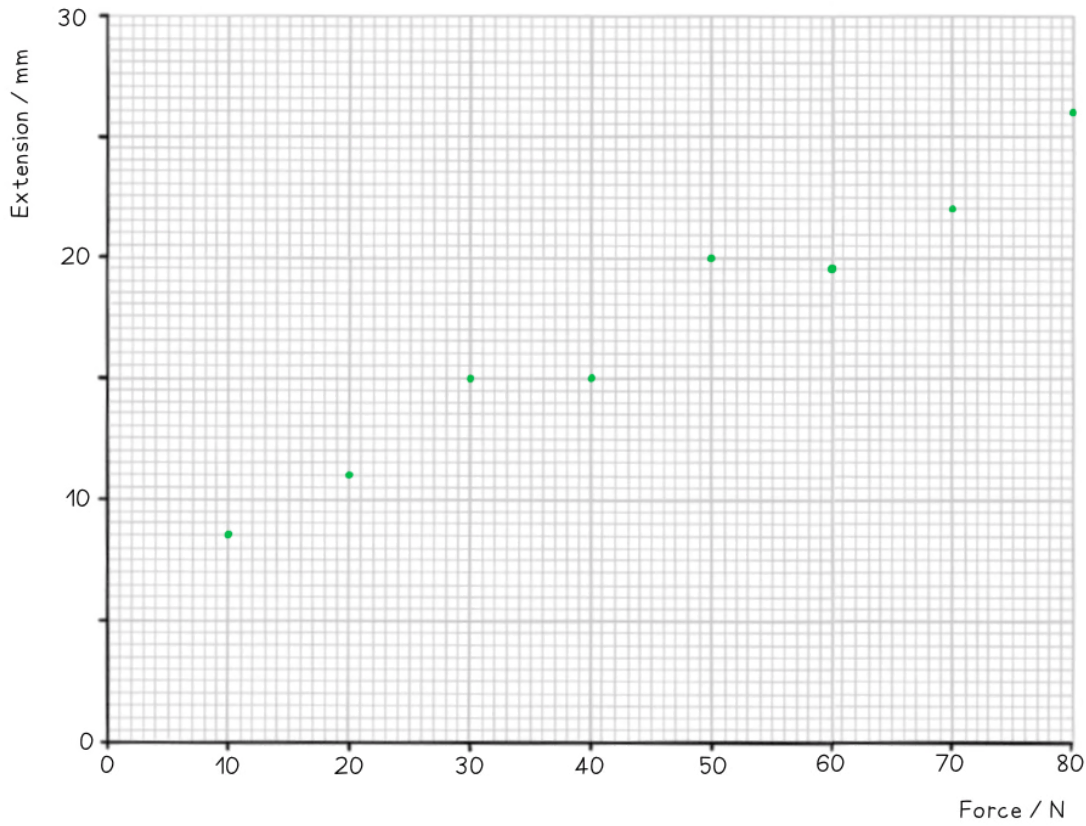

YOUR NOTES



Step 2: Draw the errors bars for each point

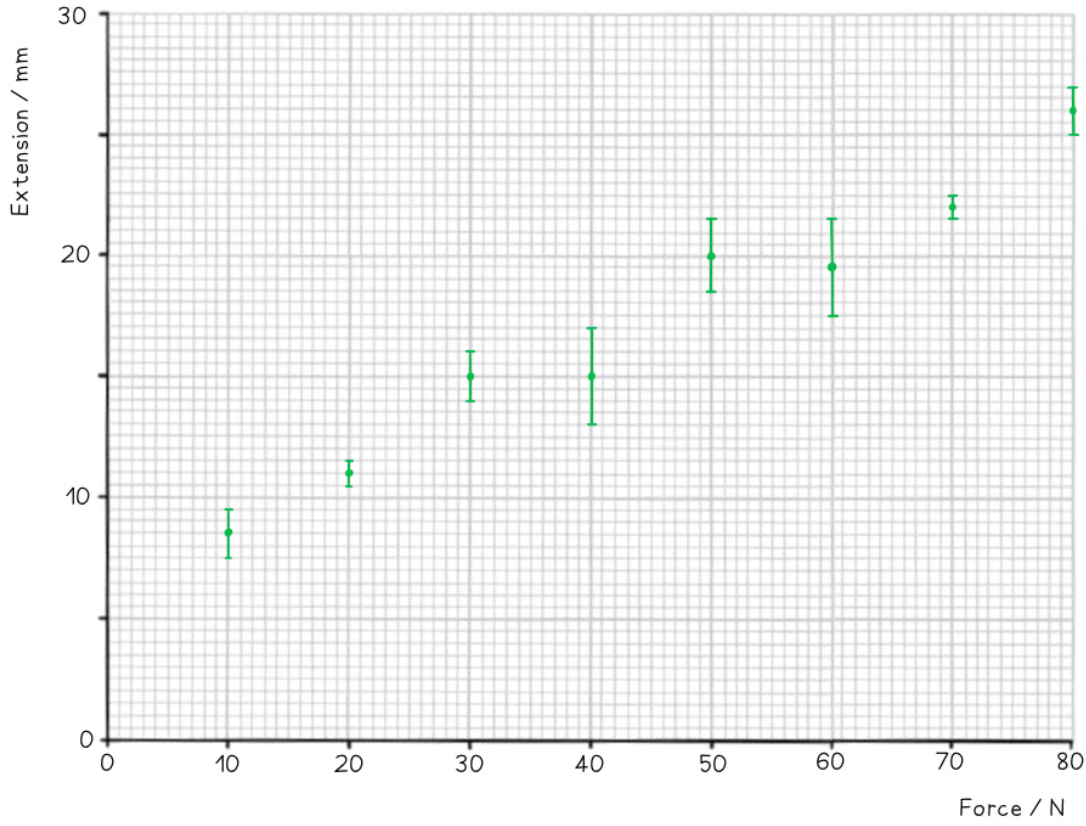

YOUR NOTES



Step 3: Draw the line of best fit

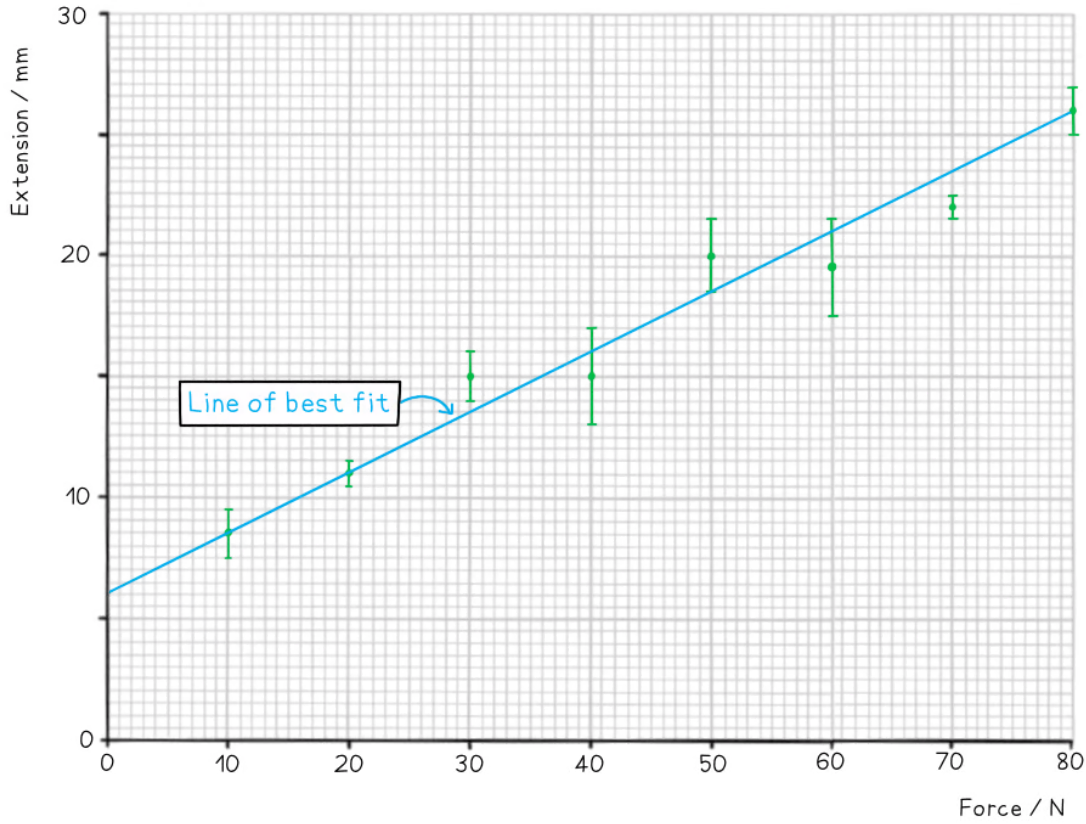

YOUR NOTES



Step 4: Draw the line of worst fit

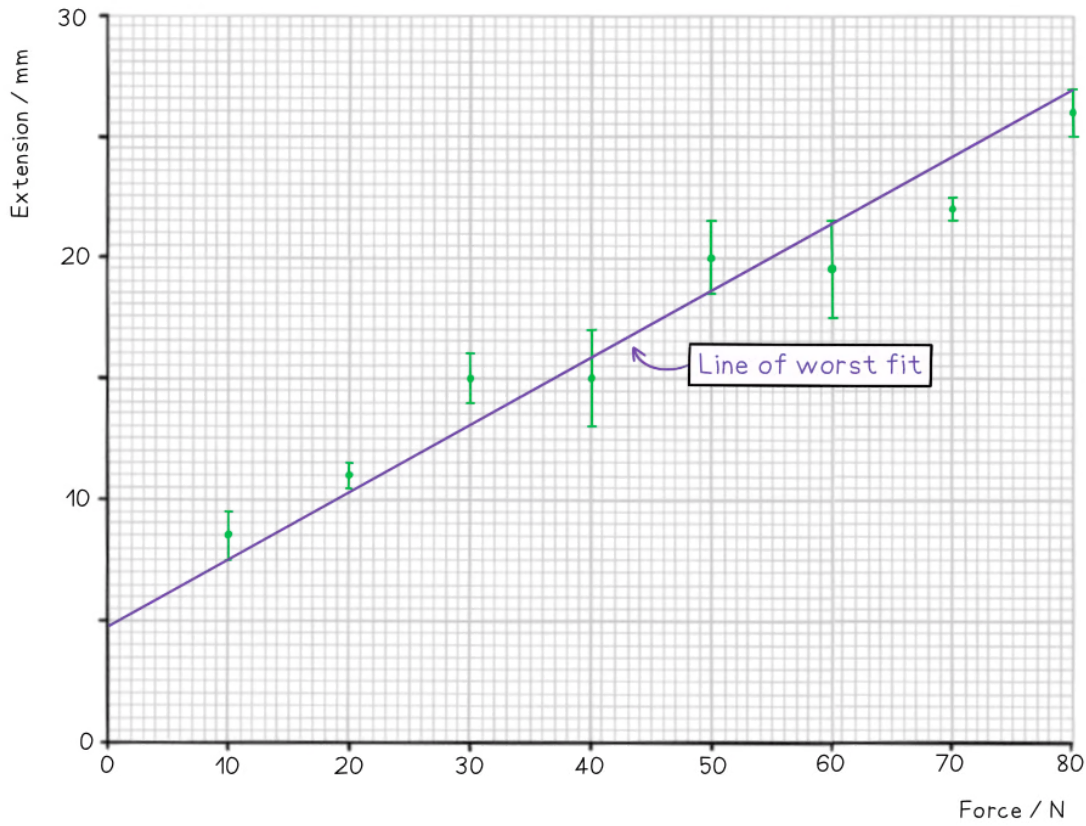

YOUR NOTES



Step 5: Work out the gradient of each line and calculate the percentage uncertainty

YOUR NOTES

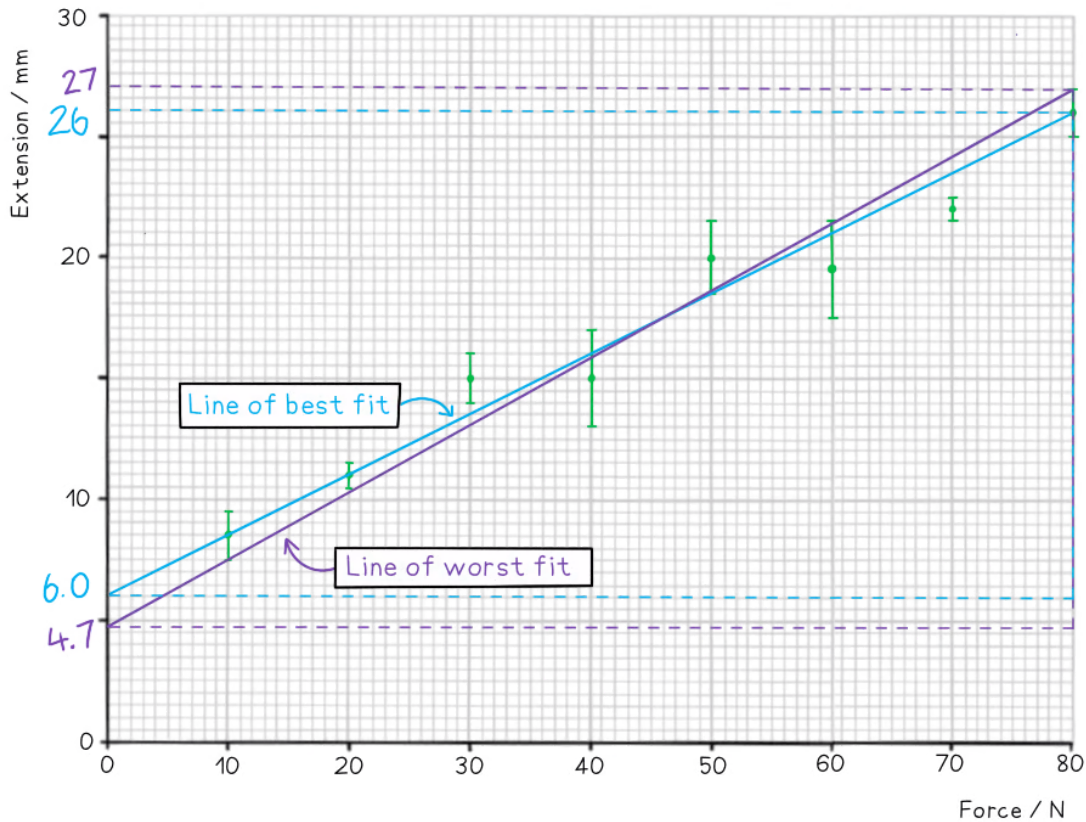

$$\text{Best gradient} = \frac{\Delta y}{\Delta x} = \frac{26 - 6}{80 - 0} = 0.25$$

$$\text{Worst gradient} = \frac{\Delta y}{\Delta x} = \frac{27 - 4.7}{80 - 0} = 0.28$$

$$\text{Percentage uncertainty} = \frac{0.28 - 0.25}{0.25} \times 100\% = 12\%$$

1.3 Vectors & Scalars

1.3.1 Vector & Scalar Quantities

YOUR NOTES



Vector & Scalar Quantities

- A **scalar** is a quantity which **only** has a magnitude (size)
- A **vector** is a quantity which has **both** a **magnitude** and a **direction**
- For example, if a person goes on a hike in the woods to a location which is a couple of miles from their starting point
 - As the crow flies, their **displacement** will only be a few miles but the **distance** they walked will be much longer

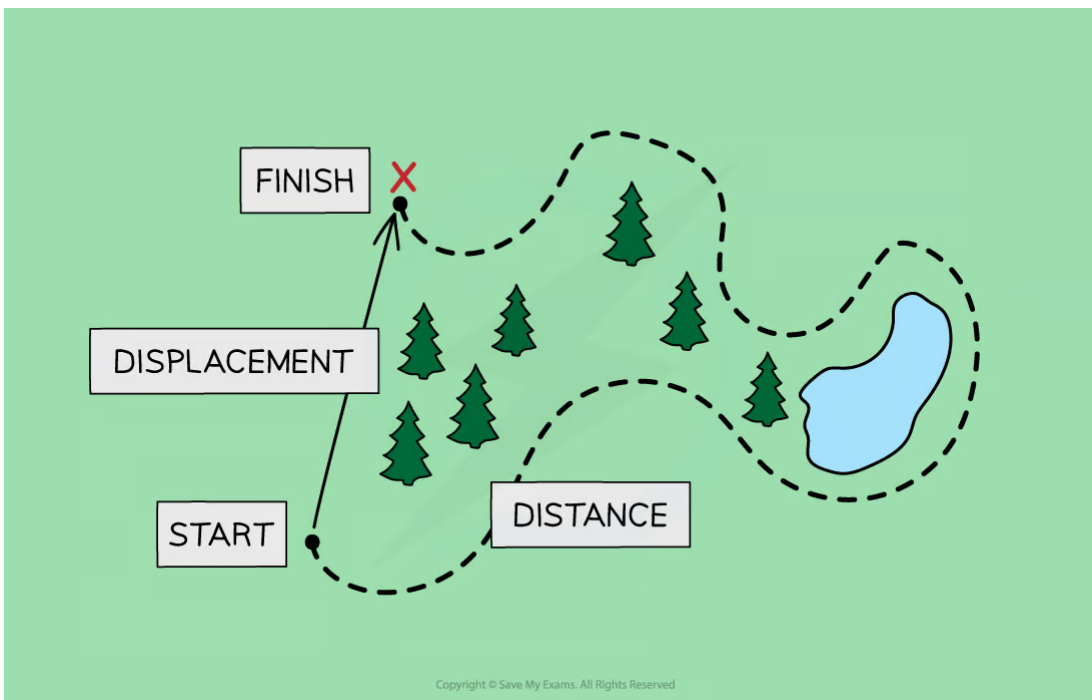

Displacement is a vector while distance is a scalar quantity

- **Distance** is a **scalar** quantity
 - This is because it describes how an object has travelled overall, but not the direction it has travelled in
- **Displacement** is a **vector** quantity
 - This is because it describes how far an object is from where it started and in what direction
- Some common scalar and vector quantities are shown in the table below:

Scalars and Vectors Table

SCALARS	VECTORS
DISTANCE	DISPLACEMENT
SPEED	VELOCITY
MASS	ACCELERATION
TIME	FORCE
ENERGY	MOMENTUM
VOLUME	
DENSITY	
PRESSURE	
ELECTRIC CHARGE	
TEMPERATURE	

Copyright © Save My Exams. All Rights Reserved

YOUR NOTES



Exam Tip

Do you have trouble figuring out if a quantity is a vector or a scalar? Just think - can this quantity have a minus sign? For example - can you have negative energy? No. Can you have negative displacement? Yes!

1.3.2 Combining & Resolving Vectors

YOUR NOTES



Combining & Resolving Vectors

- **Vectors** are represented by an arrow
 - The **arrowhead** indicates the **direction** of the vector
 - The **length** of the arrow represents the **magnitude**

Combining Vectors

- Vectors can be combined by **adding** or **subtracting** them to produce the **resultant vector**
 - The **resultant vector** is sometimes known as the 'net' vector (eg. the net force)
- There are two methods that can be used to combine vectors: the **triangle method** and the **parallelogram method**
- To combine vectors using the triangle method:
 - **Step 1:** link the vectors head-to-tail
 - **Step 2:** the resultant vector is formed by connecting the tail of the first vector to the head of the second vector
- To combine vectors using the parallelogram method:
 - **Step 1:** link the vectors tail-to-tail
 - **Step 2:** complete the resulting parallelogram
 - **Step 3:** the resultant vector is the diagonal of the parallelogram



Worked Example

Draw the vector $c = a + b$

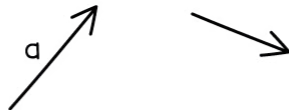

TRIANGLE METHOD

STEP 1: LINK THE VECTORS HEAD-TO-TAIL

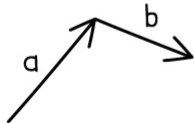

STEP 2: FORM THE RESULTANT VECTOR FROM LINKING THE TAIL OF a TO THE HEAD OF b

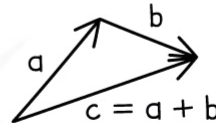

PARALLELOGRAM METHOD

STEP 1: LINK THE VECTORS TAIL-TO-TAIL

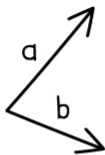

STEP 2: COMPLETE THE RESULTING PARALLELOGRAM

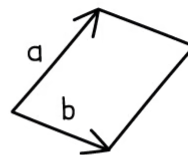

STEP 3: THE RESULTANT VECTOR IS THE DIAGONAL OF THE PARALLELOGRAM

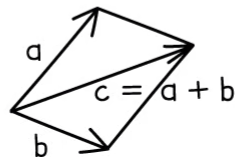

Copyright © Save My Exams. All Rights Reserved



Worked Example

Draw the vector $c = a - b$

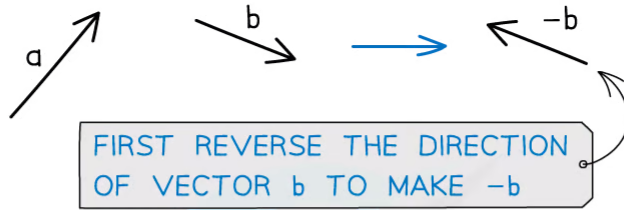

TRIANGLE METHOD

STEP 1: LINK THE VECTORS HEAD-TO-TAIL

STEP 2: FORM THE RESULTANT VECTOR BY LINKING THE TAIL OF a TO THE HEAD OF -b

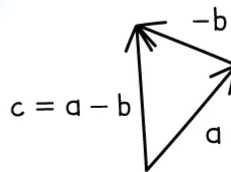

PARALLELOGRAM METHOD

STEP 1: LINK THE VECTORS TAIL-TO-TAIL

STEP 2: COMPLETE THE RESULTING PARALLELOGRAM

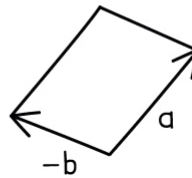
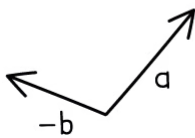

STEP 3: THE RESULTANT VECTOR IS THE DIAGONAL OF THE PARALLELOGRAM

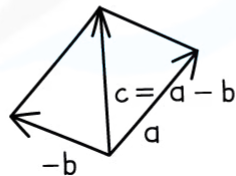

Copyright © Save My Exams. All Rights Reserved

Resolving Vectors

- Two vectors can be represented by a single **resultant vector**
 - Resolving a vector is the opposite of adding vectors
- A single resultant vector can be resolved
 - This means it can be represented by **two** vectors, which in combination have the same effect as the original one

- When a single resultant vector is broken down into its **parts**, those parts are called **components**
- For example, a force vector of magnitude F and an angle of θ to the horizontal is shown below

YOUR NOTES
↓

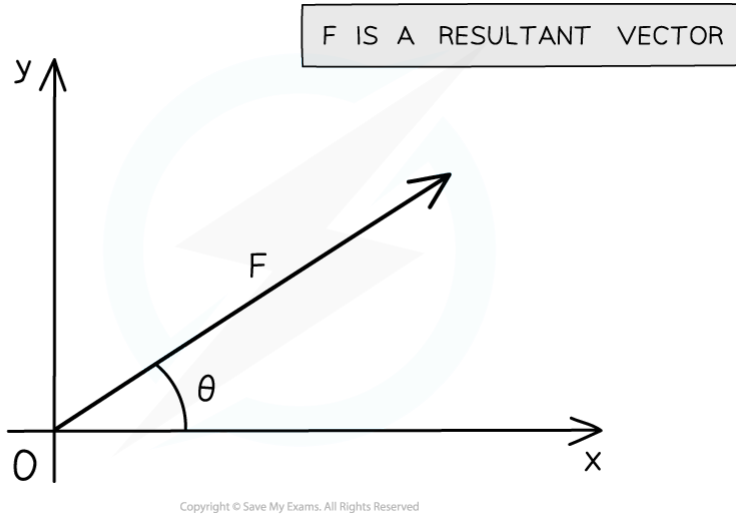

The resultant force F at an angle θ to the horizontal

- It is possible to **resolve** this vector into its **horizontal** and **vertical** components using trigonometry

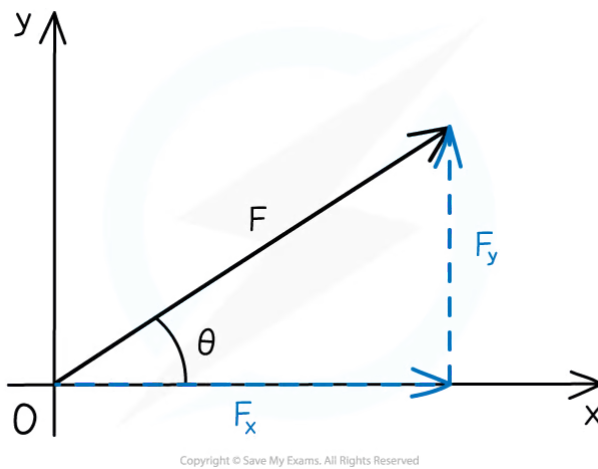

The resultant force F can be split into its horizontal and vertical components

- For the **horizontal** component, $F_x = F \cos \theta$
- For the **vertical** component, $F_y = F \sin \theta$



Worked Example

A hiker walks a distance of 6 km due east and 10 km due north.

Calculate the magnitude of their displacement and its direction from the horizontal.

Step 1: Draw a vector diagram

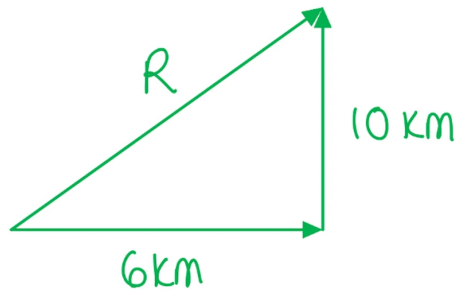

Step 2: Calculate the magnitude of the resultant vector using Pythagoras' Theorem

$$R = \sqrt{6^2 + 10^2} = 2\sqrt{34}$$

Step 3: Calculate the direction of the resultant vector using trigonometry

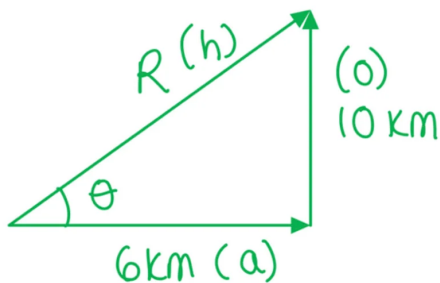

$$\tan(\theta) = \frac{\text{opposite}}{\text{adjacent}} = \frac{10}{6}$$

$$\theta = \tan^{-1}\left(\frac{10}{6}\right) = 59^\circ$$

Step 4: State the final answer complete with direction

$$R = 2\sqrt{34} = 11.66 = 12 \text{ km}$$

$\theta = 59^\circ$ east and upwards from the horizontal

YOUR NOTES



1.3.3 Solving Vector Problems

YOUR NOTES



Solving Vector Problems

- In physics, vectors appear in many different topic areas
 - Specifically, vectors are often **combined** and **resolved** to solve problems when considering motion, forces, and momentum

Forces on an Inclined Plane

- Objects on an inclined plane is a common scenario in which vectors need to be resolved
 - An inclined plane, or a slope, is a flat surface tilted at an angle, θ
- Instead of thinking of the component of the forces as horizontal and vertical, it is easier to think of them as **parallel** or **perpendicular** to the slope
- The **weight** of the object is vertically downwards and the **normal** (or reaction) force, R is always vertically up from the object
- The weight W is a vector and can be split into the following components:
 - $W \cos(\theta)$ perpendicular to the slope
 - $W \sin(\theta)$ parallel to the slope
- If there is no friction, the force $W \sin(\theta)$ causes the object to move down the slope
- If the object is not moving perpendicular to the slope, the normal force will be $R = W \cos(\theta)$

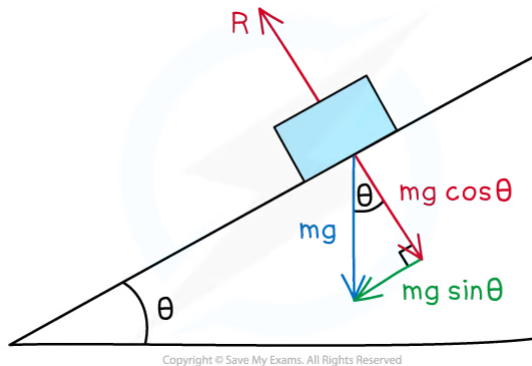

The weight vector of an object on an inclined plane can be split into its components parallel and perpendicular to the slope



? Worked Example

A helicopter provides a lift of 250 kN when the blades are tilted at 15° from the vertical.

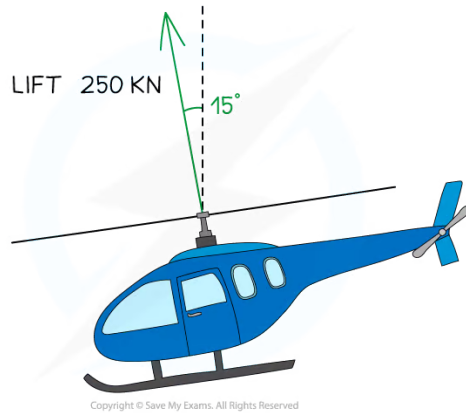

Calculate the horizontal and vertical components of the lift force.

Step 1: Draw a vector triangle of the resolved forces

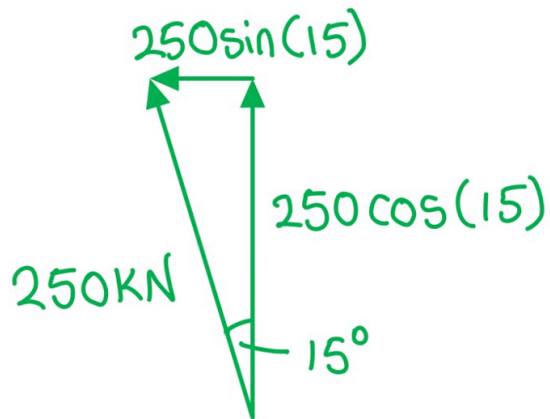

Step 2: Calculate the vertical component of the lift force

$$\text{Vertical} = 250 \times \cos(15) = 242 \text{ kN}$$

Step 3: Calculate the horizontal component of the lift force

$$\text{Horizontal} = 250 \times \sin(15) = 64.7 \text{ kN}$$



? Worked Example

A person is exploring a new part of town, from their starting point they walk 100 m in the direction 30.0° South of West. They then walk 200 m in the direction 40.0° degrees South of East and finally they walk 150 m directly East.

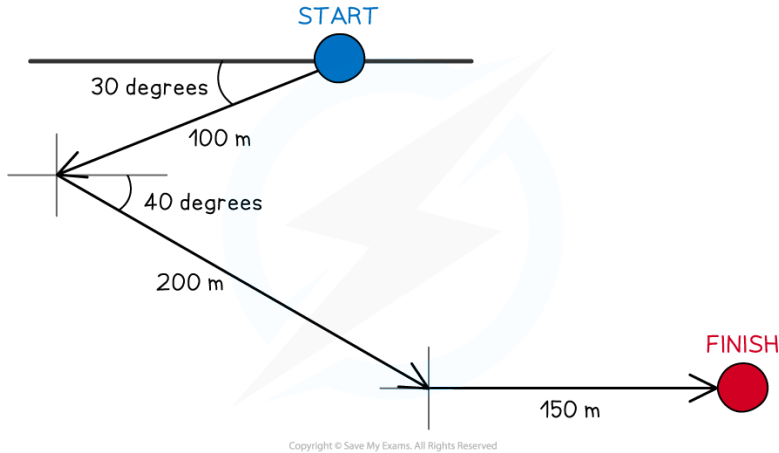

Calculate the magnitude of their displacement from their original position.

In order to calculate the answer, the vectors of displacement must be resolved into their x-components and y-components and then combined. In this case, this effectively means the x-direction is East-West and the y-direction is North-South

Step 1: Consider positive and negative directions for reference

- Since East is likely to be larger consider it the positive displacement and West as negative
- Similarly, consider South as positive and North as negative

Step 2: Resolve the first displacement (100 m magnitude) into its components

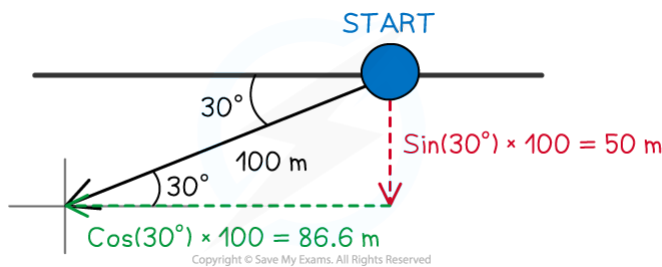

- The horizontal component can be resolved from:

$$\cos(30^\circ) \times 100 = 86.6 \text{ m}$$
- This is in a Western (negative horizontal) direction
- The vertical component can be resolved from:

$$\sin(30^\circ) \times 100 = 50.0 \text{ m}$$
- This is in a Southern (positive vertical) direction



Step 3: Resolve the second displacement (200 m magnitude) into its components

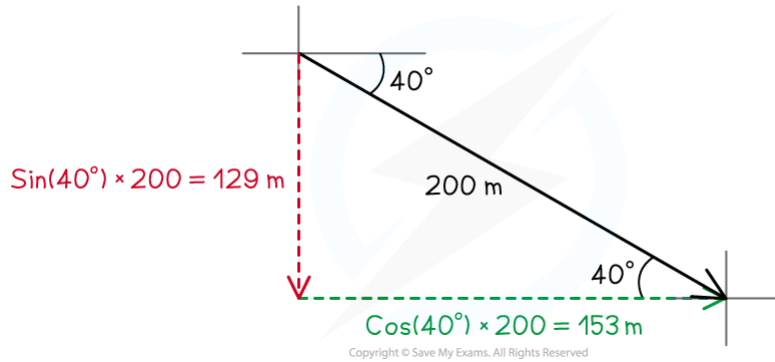

- The horizontal component can be resolved from:
 $\cos(40^\circ) \times 200 = 153 \text{ m}$
- This is in an Eastern (positive horizontal) direction
- The vertical component can be resolved from:
 $\sin(40^\circ) \times 200 = 129 \text{ m}$
- This is in a Southern (positive vertical) direction

Step 4: Resolve the third displacement (150 m magnitude) into its components

- The horizontal component is already resolved into
 150 m
- This is in an Eastern (positive horizontal) direction
- There is no vertical component for this vector

Step 5: Combine the horizontal (East-West) components

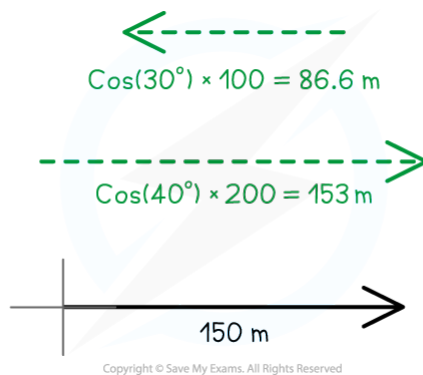

$153 + 150 - 86.6 = 166 \text{ m}$

- This is in an Eastern (positive horizontal) direction

Step 6: Combine the vertical (North-South) components

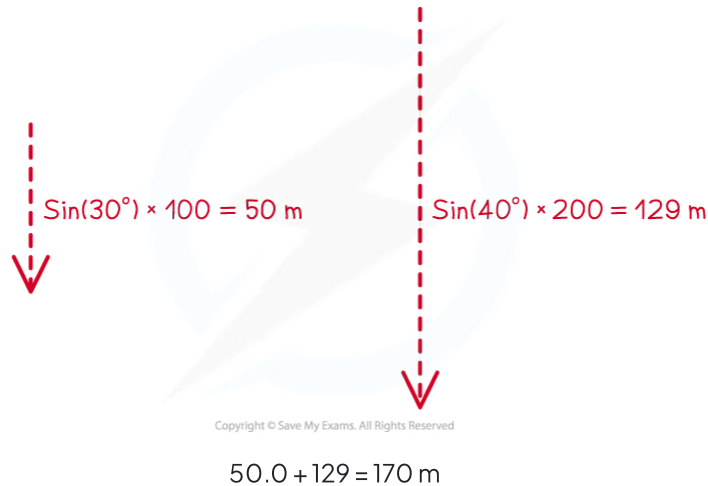

- This is in a Southern (positive vertical) direction

Step 7: Using Pythagoras theorem to find the resultant hypotenuse vector

$$\sqrt{(166^2 + 179^2)} = 244 \text{ m}$$

Equilibrium

- Coplanar forces can be represented by vector triangles
- Forces are in equilibrium if an object is either
 - At rest
 - Moving at **constant** velocity
- In equilibrium, coplanar forces are represented by **closed** vector triangles
 - The vectors, when joined together, form a closed path
- The most common forces on objects are
 - Weight
 - Normal reaction force
 - Tension (from cords and strings)
 - Friction
- The forces on a body in equilibrium are demonstrated below:

YOUR NOTES





A VEHICLE IS AT REST ON A SLOPE AND HAS THREE FORCES ACTING ON IT TO KEEP IT IN EQUILIBRIUM

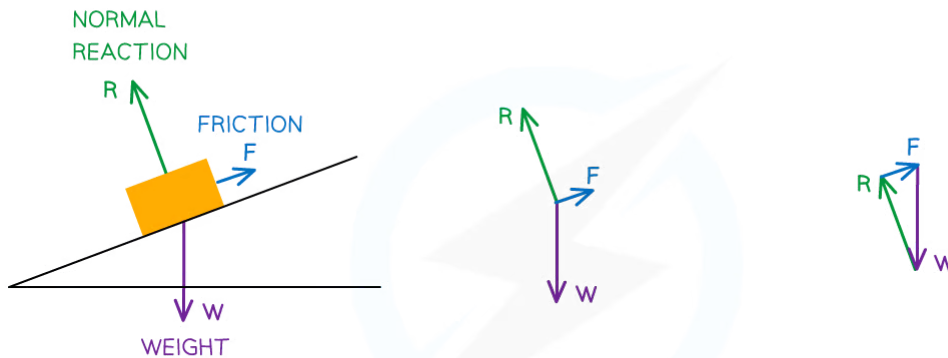

STEP 1:
DRAW ALL THE FORCES ON THE FREE-BODY DIAGRAM

STEP 2:
REMOVE THE OBJECT AND PUT ALL THE FORCES COMING FROM A SINGLE POINT

STEP 3:
REARRANGE THE FORCES INTO A CLOSED VECTOR TRIANGLE. KEEP THE SAME LENGTH AND DIRECTION

Copyright © Save My Exams. All Rights Reserved

Three forces on an object in equilibrium form a closed vector triangle

? Worked Example

A weight hangs in equilibrium from a cable at point X. The tensions in the cables are T_1 and T_2 as shown.

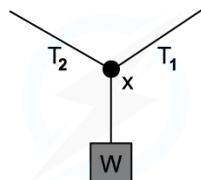

Copyright © Save My Exams. All Rights Reserved

Which diagram correctly represents the forces acting at point X?

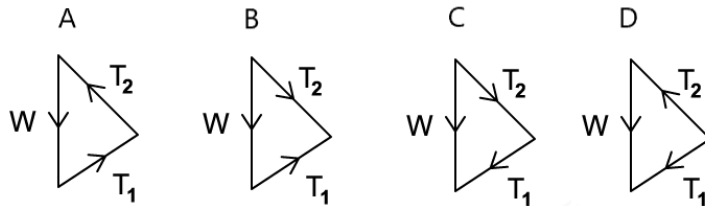



ANSWER: **A**

STEP 1

IDENTIFY THE DIRECTION OF ALL THE FORCES

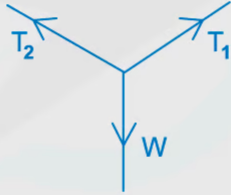

STEP 2

ARRANGE THESE INTO A VECTOR TRIANGLE KEEPING THE SAME MAGNITUDE AND DIRECTIONS

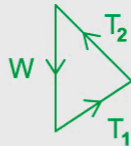

STEP 3

ENSURE THE DIRECTION OF THE VECTORS FORM A CLOSED PATH

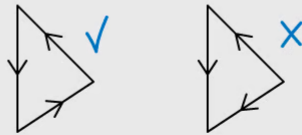

Copyright © Save My Exams. All Rights Reserved



Exam Tip

If you're unsure as to which component of the force is $\cos \theta$ or $\sin \theta$, just remember that the $\cos \theta$ is always the adjacent side of the right-angled triangle AKA, making a 'cos sandwich'

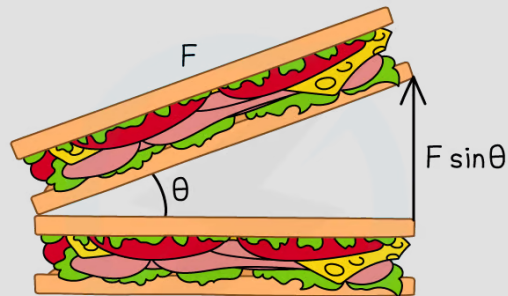

"cos SANDWICH"

Copyright © Save My Exams. All Rights Reserved

