

2.4 Enzymes

Question Paper

Course	DP IB Biology
Section	2. Molecular Biology
Topic	2.4 Enzymes
Difficulty	Medium

Time allowed: 60
Score: /42
Percentage: /100

Question 1a

- a) Lipase is an enzyme that breaks down lipids. The diagram below shows an experiment set up by a teacher to investigate the effect of lipase concentration on the hydrolysis of lipids.

The pH of beaker B is measured for 3 minutes at the start of the experiment. Beaker A containing lipase solution is added to beaker B. The data logger recorded the change in pH over the next 5 minutes.

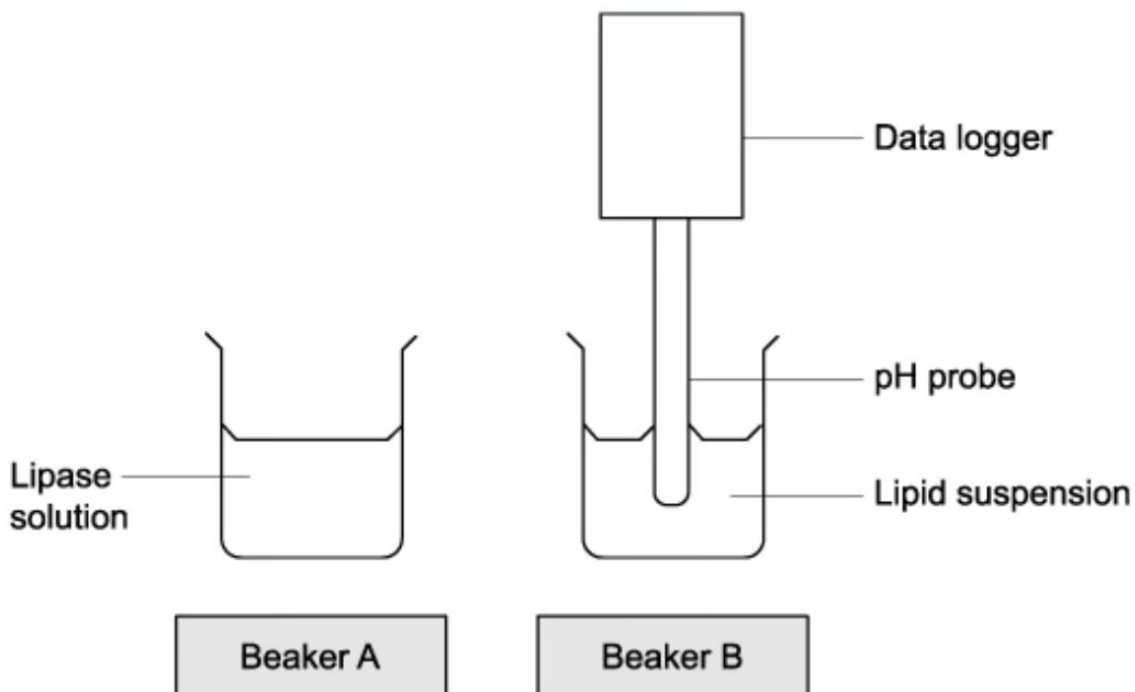

State, with a reason, the predicted change in pH after the lipase has been added.

[3 marks]

Question 1b

- b) State **two** variables that must be controlled to carry out the experiment in part (a) accurately and reliably.

[2 marks]

Question 1c

- c) For the experiment in part (a), draw a results table that could be used to record the results of the investigation. Your table should include suggested enzyme concentrations, and units should be stated.

[3 marks]

Question 2a

- a) A protease is an enzyme that digests protein. A research scientist isolated protease **C** from a particular species of bacteria. The researcher investigated the effect of temperature on the rate of hydrolysis of a protein by protease **C**. The unprocessed results can be seen in the table below.

Temperature / °C	Mass of protein hydrolysed after 4 minutes / mg	Rate of hydrolysis /
10	470	
15	990	
20	1 180	
25	1 310	
35	1 030	
45	420	
60	110	

Calculate (with appropriate units) the missing details in the table above.

[2 marks]

Question 2b

- b) Draw a graph of the results seen in part (a). Your graph should include an accurate scale and correct axis labels.

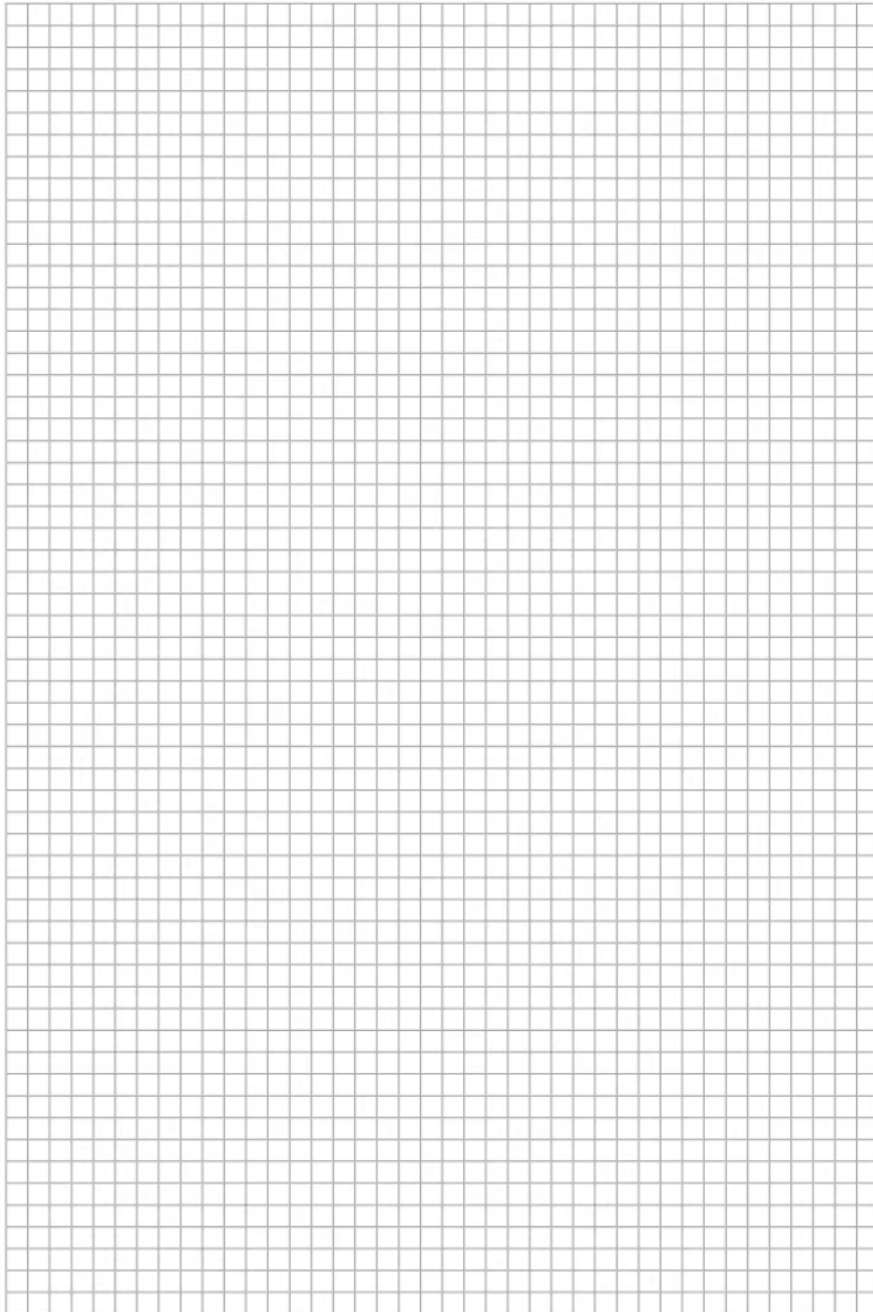

[4 marks]

Question 2c

- c) Suggest how the research scientist controlled the pH throughout the experiment.

[1 mark]

Question 3a

- a) Explain the aspect of enzyme and substrate structure that enables successful catalysis of a biochemical reaction.

[2 marks]

Question 3b

- b) The sketch graph below shows how the rate of an enzyme-catalysed reaction varies for two separate independent variables. For curve **A** the independent variable is the concentration of enzyme.

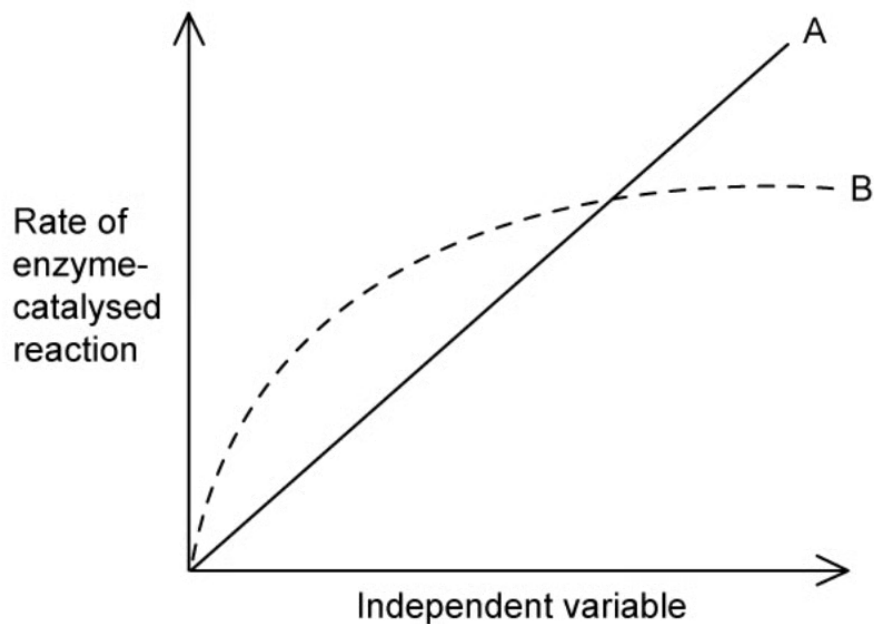

Identify the independent variable for Curve **B**.

[1 mark]

Question 3c

- c) The sketch graph below shows how the rate of an enzyme-catalysed reaction varies as temperature changes.

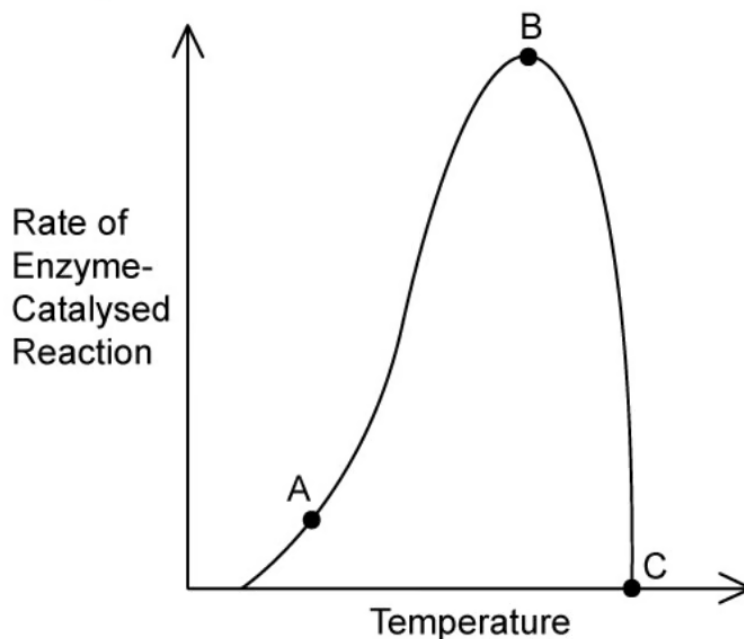

Explain the rates of reaction at positions **A**, **B**, and **C** on the curve.

[3 marks]

Question 4a

- a) Enzymes can be used in various industrial processes.

Suggest **one** reason why the use of enzymes in industry offers a commercial benefit over non-enzymatic processes.

[1 mark]

Question 4b

- b) The diagram below shows a typical packed-bed immobilised enzyme reactor for a continuous production process in the food industry.

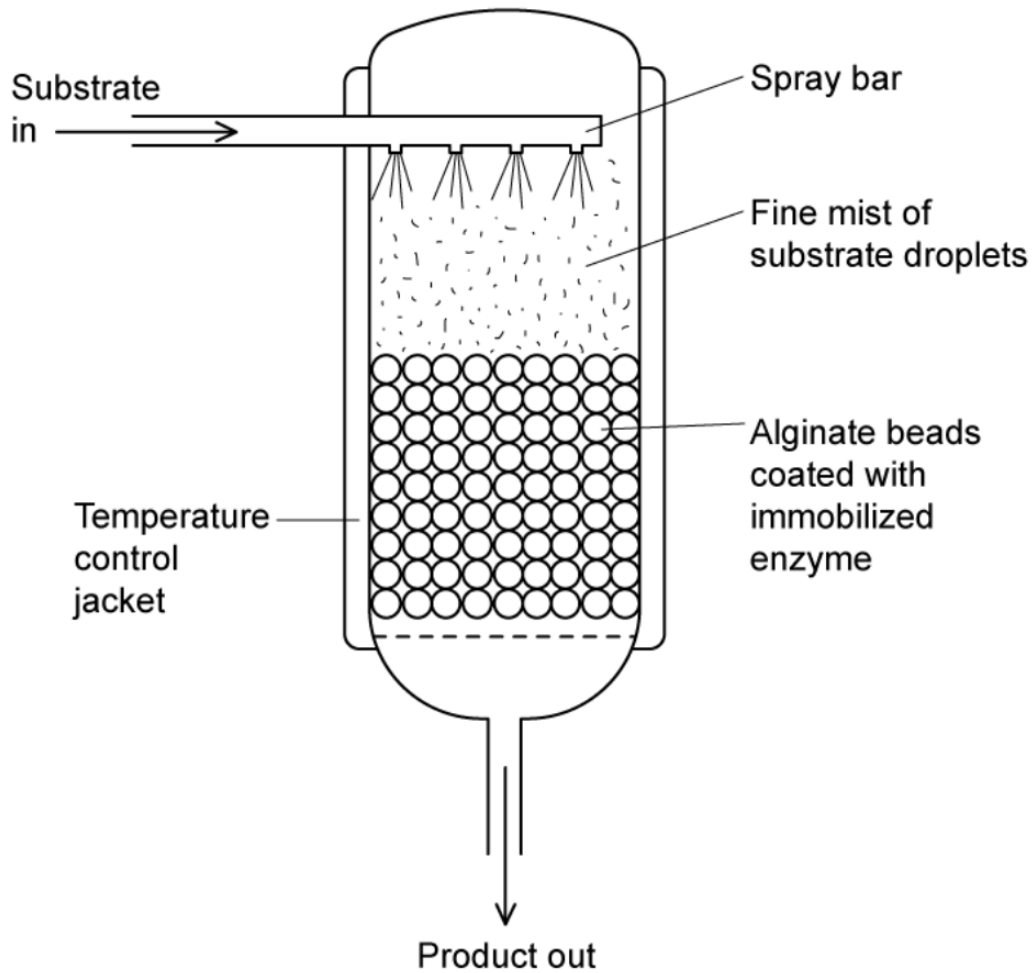

State **three** benefits of using immobilised enzymes, as opposed to enzymes that are allowed to mix freely with the substrate.

[3 marks]

Question 4c

- c) The process of binding an enzyme to an immobile matrix for the purposes of enzyme immobilisation has, in some cases, led to a reduction in the enzyme's activity level.

Suggest, with a reason, how the process of immobilisation could cause the change in enzyme activity after immobilisation.

[2 marks]

Question 5a

One mark is available for clarity of communication throughout this question.

- a) The sketch graph below shows the effects of varying the level of the independent variable, X, on the rate of an enzyme-controlled reaction. Lines **A**, **B**, and **C** represent three different independent variables which could be X.

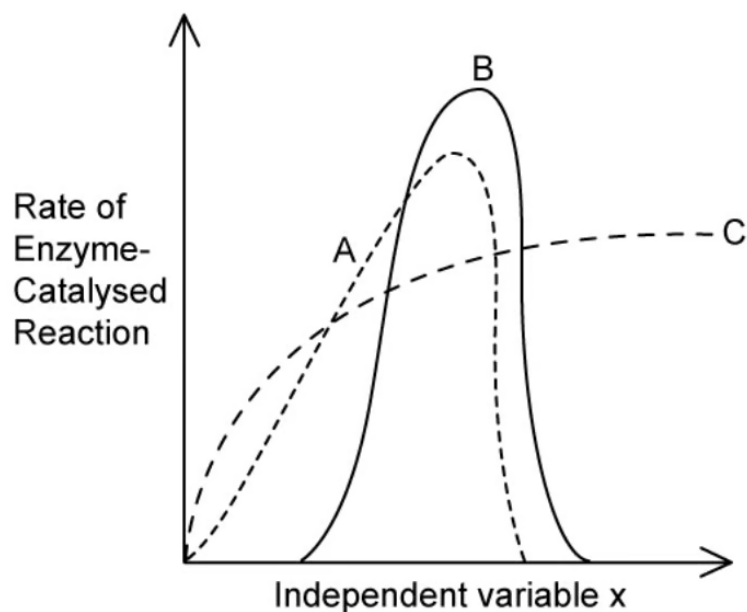

(i) Identify the independent variables that would cause lines **A**, **B**, and **C**.

(ii) Use your knowledge of enzyme activity to explain the changes in reaction rate shown by lines **A**, **B** and **C**.

[7 marks]

Question 5b

- b) Outline the method used in the production of lactose-free milk from dairy milk.

[4 marks]

Question 5c

- c) An experiment was set up to investigate the effect of temperature on an enzyme-catalysed reaction in which the reaction mixture changes from clear-colourless to clear-dark blue as the reaction progresses.

Describe:

- (i) How the independent variable in the experiment could be controlled.
- (ii) How a colorimeter could be used to measure colour change.

[4 marks]



Head to [savemyexams.co.uk](https://www.savemyexams.co.uk) for more awesome resources