



Candidates must complete this page and then give this cover and their final version of the extended essay to their supervisor.

Candidate session number

Candidate name

School name

Examination session (May or November)

MAY

Year

2015

Diploma Programme subject in which this extended essay is registered:

PHYSICS

(For an extended essay in the area of languages, state the language and whether it is group 1 or group 2.)

Title of the extended essay:

The Effect of Temperature on the Surface Tension of Water

### Candidate's declaration

*This declaration must be signed by the candidate; otherwise a mark of zero will be issued.*

The extended essay I am submitting is my own work (apart from guidance allowed by the International Baccalaureate).

I have acknowledged each use of the words, graphics or ideas of another person, whether written, oral or visual.

I am aware that the word limit for all extended essays is 4000 words and that examiners are not required to read beyond this limit.

This is the final version of my extended essay.

Candidate's signature:

Date:

Jan. 29, 2015

## Supervisor's report and declaration

The supervisor must complete this report, sign the declaration and then give the final version of the extended essay, with this cover attached, to the Diploma Programme coordinator.

Name of supervisor (CAPITAL letters) \_\_\_\_\_

Please comment, as appropriate, on the candidate's performance, the context in which the candidate undertook the research for the extended essay, any difficulties encountered and how these were overcome (see page 13 of the extended essay guide). The concluding interview (viva voce) may provide useful information. These comments can help the examiner award a level for criterion K (holistic judgment). Do not comment on any adverse personal circumstances that may have affected the candidate. If the amount of time spent with the candidate was zero, you must explain this, in particular how it was then possible to authenticate the essay as the candidate's own work. You may attach an additional sheet if there is insufficient space here.

began by coming to me with an interesting device for measuring surface tension. I suggested she brainstorm and research factors that affect surface tension, and she came up with temperature. While not mentioned, she placed the water in an insulated cup (usually used for calorimetry), which made the rate of change of the water slow enough to easily measure. I was incredibly impressed with her ideas and her reaction to problems. If you look closely, you can see that the diagrams were all drawn by hand and scanned in. Very impressive! ✓

This declaration must be signed by the supervisor; otherwise a mark of zero will be issued.

I have read the final version of the extended essay that will be submitted to the examiner.

To the best of my knowledge, the extended essay is the authentic work of the candidate.

As per the section entitled "Responsibilities of the Supervisor" in the EE guide, the recommended number of hours spent with candidates is between 3 and 5 hours. Schools will be contacted when the number of hours is left blank, or where 0 hours are stated and there lacks an explanation. Schools will also be contacted in the event that number of hours spent is significantly excessive compared to the recommendation.

I spent  hours with the candidate discussing the progress of the extended essay.

Supervisor's signature: \_\_\_\_\_

Date: Feb. 3 / 2015

**Assessment form (for examiner use only)**

|                          |  |  |
|--------------------------|--|--|
| Candidate session number |  |  |
|--------------------------|--|--|

**Achievement level**

| Criteria                      | Examiner 1                      | maximum | Examiner 2           | maximum | Examiner 3           |
|-------------------------------|---------------------------------|---------|----------------------|---------|----------------------|
| A research question           | <input type="text" value="2"/>  | 2       | <input type="text"/> | 2       | <input type="text"/> |
| B introduction                | <input type="text" value="2"/>  | 2       | <input type="text"/> | 2       | <input type="text"/> |
| C investigation               | <input type="text" value="3"/>  | 4       | <input type="text"/> | 4       | <input type="text"/> |
| D knowledge and understanding | <input type="text" value="2"/>  | 4       | <input type="text"/> | 4       | <input type="text"/> |
| E reasoned argument           | <input type="text" value="3"/>  | 4       | <input type="text"/> | 4       | <input type="text"/> |
| F analysis and evaluation     | <input type="text" value="2"/>  | 4       | <input type="text"/> | 4       | <input type="text"/> |
| G use of subject language     | <input type="text" value="3"/>  | 4       | <input type="text"/> | 4       | <input type="text"/> |
| H conclusion                  | <input type="text" value="1"/>  | 2       | <input type="text"/> | 2       | <input type="text"/> |
| I formal presentation         | <input type="text" value="3"/>  | 4       | <input type="text"/> | 4       | <input type="text"/> |
| J abstract                    | <input type="text" value="1"/>  | 2       | <input type="text"/> | 2       | <input type="text"/> |
| K holistic judgment           | <input type="text" value="3"/>  | 4       | <input type="text"/> | 4       | <input type="text"/> |
| Total out of 36               | <input type="text" value="25"/> |         | <input type="text"/> |         | <input type="text"/> |

Name of examiner 1: \_\_\_\_\_ Examiner number: \_\_\_\_\_  
(CAPITAL letters)

Name of examiner 2: \_\_\_\_\_ Examiner number: \_\_\_\_\_  
(CAPITAL letters)

Name of examiner 3: \_\_\_\_\_ Examiner number: \_\_\_\_\_  
(CAPITAL letters)

IB Assessment Centre use only: B:

IB Assessment Centre use only: A:

The Effect of Temperature on the Surface  
Tension of Water ✓

Subject: Physics

Total Word Count: 3876 ✓

## Abstract

*rd*  
The purpose of this experiment was to investigate the effect of temperature on the surface tension of water. Surface tension is the force per unit length required to extend the surface of a liquid. It was hypothesised that the surface tension of water would decrease as temperatures increased. This is supported by the model derived by Eötvös and the variation of Eötvös' model proposed by Ramay and Shields.

*how  
was it ...*  
To investigate the surface tension of water, the force required to lift a wire frame from the surface of water was measured using a balance. This force was then used to calculate the surface tension of the water. Temperatures investigated ranged from 3°C to 78°C, taken at frequent intervals as the water approached room temperature. Measurements for temperature were taken immediately after the measurements for the force of surface tension.

*concl.*  
The results of the experiment supported the hypothesis. The linear mathematical model representing the data collected has a slope that is very similar to the Eötvös and Ramay-Shields equations. However, the surface tension was found to be significantly lower at any given temperature.

Word Count: 181 ✓

1/2

2nd element: incomplete, unclear ;

- how  
temperat.  
chang  
- note  
of u  
- dislik  
- not

# Table of Contents ✓

|   |           |
|---|-----------|
| Abstract .....  | 2         |
| Table of Contents .....   | 3         |
| Introduction .....  | 4         |
| Research Question and Rationale .....                                     | 4         |
| Background .....  | 4         |
| Theories .....  | 7         |
| Hypothesis .....  | 7         |
| Controlled Variables .....  | 8         |
| • Source of water .....   | 8         |
| • Contact angle between surface of water and the normal to the wire ..... | 8         |
| • Length and shape of wire .....  | 8         |
| Materials and Method .....  | 9         |
| Apparatus and Setup .....   | 9         |
| Method .....  | 11        |
| Data Collection .....   | 13        |
| Qualitative Observations .....  | 13        |
| Data processing .....   | 14        |
| Discussion .....  | 17        |
| Impact of Error .....   | 17        |
| Sources of Error and Improvements .....                                   | 18        |
| • Solutes and Containments in Water .....                                 | 18        |
| • Temperature Measurement .....   | 19        |
| • External Influences .....   | 19        |
| Further Investigation .....   | 20        |
| Conclusion .....  | 20        |
| Appendices .....  | <u>21</u> |
| Appendix A: Raw Data .....  | 21        |
| Appendix B: Processed Data .....  | 23        |
| Works Cited .....   | 25 ✓      |

(graphic)

## Introduction

### Research Question and Rationale

The question investigated was:

How does the temperature of water affect its surface tension?

2/2 74

Surface tension is a property of water that causes the surface to behave like a film as a result of its tendency to minimize its surface area. It is necessary for biological processes such as transpiration which allows vascular plants to transport water through xylem. (Freeman, 2007). In addition to being an important part of the natural world, surface tension has several industrial applications as well. For example, liquids with high surface tensions can be used for the self-assembly of microstructures since the force of surface tension can be used to move small pieces of material in specific ways. (Syms, Yeatman, Bright, & Whitesides, 2003). The behaviour of a liquid can be predicted based on its surface tension. Factors that affect the surface tension of pure liquids include its polarity, density, temperature. (Vowell, 2009; Alizadeh Osgouei, Parsafar, & Akbarzadeh, 2011). The surface tension of solutions also depends on the solute. (Chen & Smith, 2008). The aim of this study was to investigate the property of the surface tension of water at different temperatures in order to better understand the behaviour of water under different conditions. Since temperature is difficult to control, knowledge of surface tension at a variety of temperatures is especially useful because it allows for adjustments to be made based on temperature rather than trying to control temperature. -

### Background

Surface tension is defined as the force ( $F$ ) per unit length ( $L$ ) required to extend the surface of a liquid. (Cutnell & Johnson, 2006).

Figure 1: Surface Tension Definition

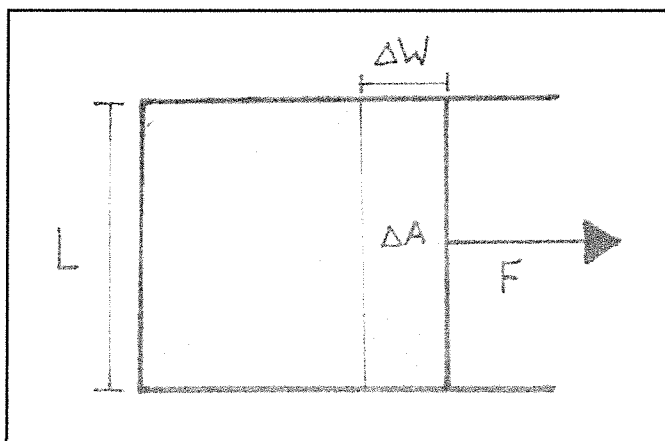

(Lautrup, 2009)

Surface energy, which is a measure of the energy required to increase the surface area of a liquid by a unit area ( $\text{J m}^{-2}$ ), can help illustrate the concept of surface tension. (Surface tension). Surface energy is equal to the surface tension of the liquid (measured in  $\text{N m}^{-1}$ ) because

$$\text{Surface Energy} = \frac{\Delta E}{\Delta A}$$

(Lautrup, 2009)

$\Delta E$  is the change in energy stored by the surface,  $\Delta A$  is the change in area of the film and  $\Delta W$  is the change in width, both as indicated in figure 1.

$$SE = \frac{F \cdot \Delta W}{L \cdot \Delta W}$$

$$SE = \frac{F}{L}$$

Since

$$\text{Surface Tension} = \frac{F}{L}$$

(Duxbury, 2005) ? not in textbooks

$$\text{Surface Tension} = \text{Surface Energy}$$

When calculating surface tension, the equation

$$\gamma = \frac{F}{2L}$$

is used in order to account for the increase in surface area on both sides of the film.

Surface tension can be observed as the surface of liquid behaving like a thin, flexible membrane. This is the result of a liquid's tendency to maintain a minimal surface area. This is caused by an imbalance of cohesive forces at the surface of the liquid. (Ghosh, 2012). Cohesive forces are attractive forces between molecules of the same kind. In water, hydrogen bonds are responsible for cohesion between the water molecules. (Chaplin, 2007). Within the bulk of a liquid, each molecule is attracted by all of the molecules around it. (Ghosh, 2012). This means that the net force on each molecule is zero. However, a molecule at the liquid-gas interface will only experience cohesive forces on one side, assuming that gas is an ideal gas that has no intermolecular forces. Therefore, there will be a net force perpendicular to the surface of the



liquid acting upon molecules at the surface. (Definition of interface liquid-gas and liquid-liquid interfaces, 2012). Figure 2 shows intermolecular forces acting on molecules within the bulk and at the surface of a liquid.

Figure 2: Intermolecular Forces

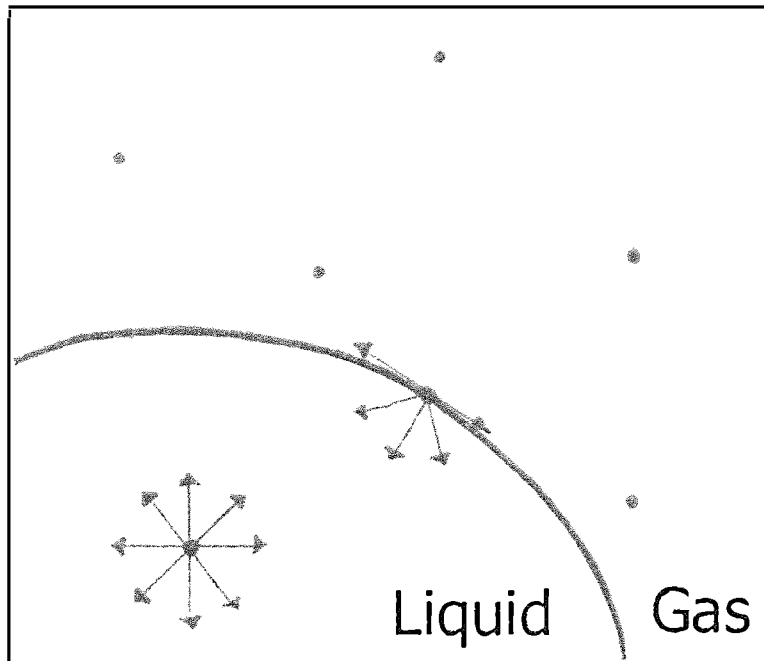

Due to the force imbalance at the surface of the liquid, molecules at the surface store energy. The total energy stored is represented by

$$E = \gamma S$$

$$\left( \frac{J}{m} \times m^2 \right)$$

Where  $E$  is the energy stored by the surface,  $\gamma$  is the surface tension, and  $S$  is the surface area. (Vowell, 2009). Since the energy stored by the surface is proportional to the surface area, minimizing the surface area will minimize energy stored by the surface. This explains why, in the absence of external forces, a liquid will minimize its surface area: in order to arrive at the state of least potential energy. (Vowell, 2009). Thus, work must be done in order to increase the surface area of a liquid because of the increase in the potential energy of the surface.

intro: 2/2

## Theories

The Eötvös rule states that for any liquid:

$$\gamma = \frac{k(T_c - T)}{V_m^{2/3}}$$

-  $T_c$  ni ?  
- type of water ?

(Definition of interface liquid-gas and liquid-liquid interfaces, 2012)

Where  $T_c$  is the critical temperature,  $T$  is the temperature and  $V_m$  is the molar volume of the liquid. The critical temperature is the temperature at which liquid-gas interface disappears. The molar volume is the volume of one mole of the liquid and is measured in  $\text{m}^3 \text{mol}^{-1}$ .  $k$  is a constant equal to approximately  $2.12 \times 10^{-7} \text{ J mol}^{-2/3} \text{ K}^{-1}$ . (Definition of interface liquid-gas and liquid-liquid interfaces, 2012). This model, which was derived based on empirical evidence, assumes that the surface tension of any liquid decreases linearly with temperature. It is also assumed that thermal expansion is negligible so that the molar volume will be the same regardless of temperature. While this equation accurately predicts the temperature dependency of surface tension for most liquids, it is not the only method nor is it necessarily the most accurate. A variation of the Eötvös rule suggested by Ramay and Shields proposes that

$$\gamma = \frac{k(T_c - T - 6)}{V_m^{2/3}}$$

(Ghosh, 2012)

This model more accurately predicts the surface tension at lower temperatures when the gas begins to deviate from ideal behaviour. However, it also predicts the disappearance of the liquid-gas interface at 6 K lower than the critical temperature.

## Hypothesis

If the temperature increases, the surface tension will decrease because the strength of intermolecular forces between water molecules decreases as temperature increases. The cohesive force in water results primarily from hydrogen bonds between water molecules. (Hipschman, 1995). The strength of hydrogen bonds depend its length; as the bond length increases, the strength decreases. (Chaplin, 2007). As temperature increases, water molecules gain kinetic energy and move away from each other. (Chaplin, 2007). Hence as the temperature of water increases, the hydrogen bond length between water molecules increases and the hydrogen bond strength decreases. Therefore, surface tension should decrease as temperature increases since it is a measure of the strength of cohesive forces. This is consistent with both models presented in the section above.

$\frac{D}{\rho}$  \*  
 $T_c$ : any value?  
if  $T = T_c$   
 $\Rightarrow \gamma = 0$

gas & liquid at same temperature?

\* how water molecules force vary with this temperature?

## Controlled Variables

### Source of water

Water from different sources will contain different impurities that will affect the surface tension of water. Ideally, water with no impurities should be used however, as this was not available, the effect of the impurities on the data can be minimized by using water from the same source so that impurities remain the same and do not contribute to random error in the experiment.

### Contact angle between surface of water and the normal to the wire

The normal of the wire refers to a vertical, imaginary line that goes through the point of contact between the water and the wire.

If the contact angle changes, the direction that the force of surface tension comes from will change as well. Since only the vertical force is measured, the contact angle must be known in order to calculate the total force due to surface tension. Since it is difficult to measure the contact angle, it was kept at  $0^\circ$ .

### Length and shape of wire

Since surface tension is a measure of the force *per unit length* required to extend the surface of a liquid, any changes to the length of the wire will affect the value calculated for surface tension.

Furthermore, it is necessary for the shape of the wire to remain the same so that the interaction between the wire and the water will remain the same. For example, the length of wire actually touching the surface of the water will change if the horizontal section of the wire is bent. The contact angle might also change if the legs of the frame (shown in figure 5) are altered.

any data ✓  
of S.T. for  
distilled  
water ?

diagram  
G

see fig. 1

## Materials and Method

### Apparatus and Setup

Since surface tension deals with very small quantities of force and energy, it would be very difficult to measure it directly using a spring scale. Not only are most spring scales not sufficiently precise, they are also subject to human error because when measuring such small quantities of force, even the shaking of a hand will affect the accuracy of the results. Therefore instead of a spring scale, a balance was used to measure the amount of force necessary to lift a piece of wire from the surface of the water. Figure 3 shows how the balance was set up in order to measure the surface tension of the water.

Figure 3: Experiment Setup

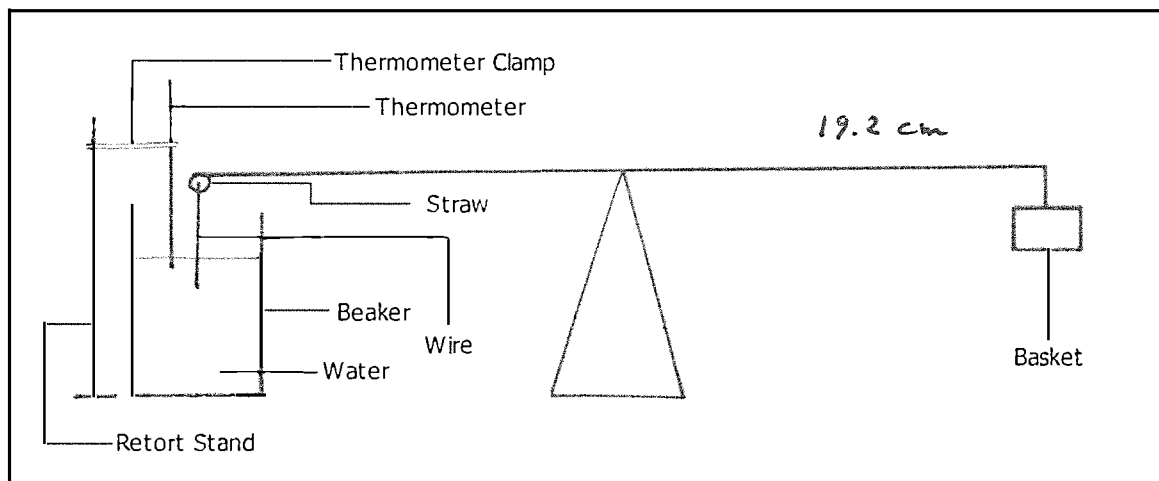

The thermometer was placed as close to the surface of the water as possible to obtain a more accurate measurement for the temperature of the surface of the water.

The two arms of the lever were made with identical plastic rods to ensure that they were the same length ( $19.2 \pm 0.1$  cm), thus ensuring that the effort force was equal to the load force. Each arm consisted of two rods to improve stability as shown in Figure 4.

The wire end of the lever was constructed such that the wire was not connected directly to the arm of the lever. Rather, it rested on a hinge that consisted of two straw segments and a toothpick. This allows the wire to remain perpendicular to the surface of the water regardless of the angle of the lever arm (see figure 4). This ensured that only the vertical forces on the wire were measured.

Figure 4: Wire End Setup

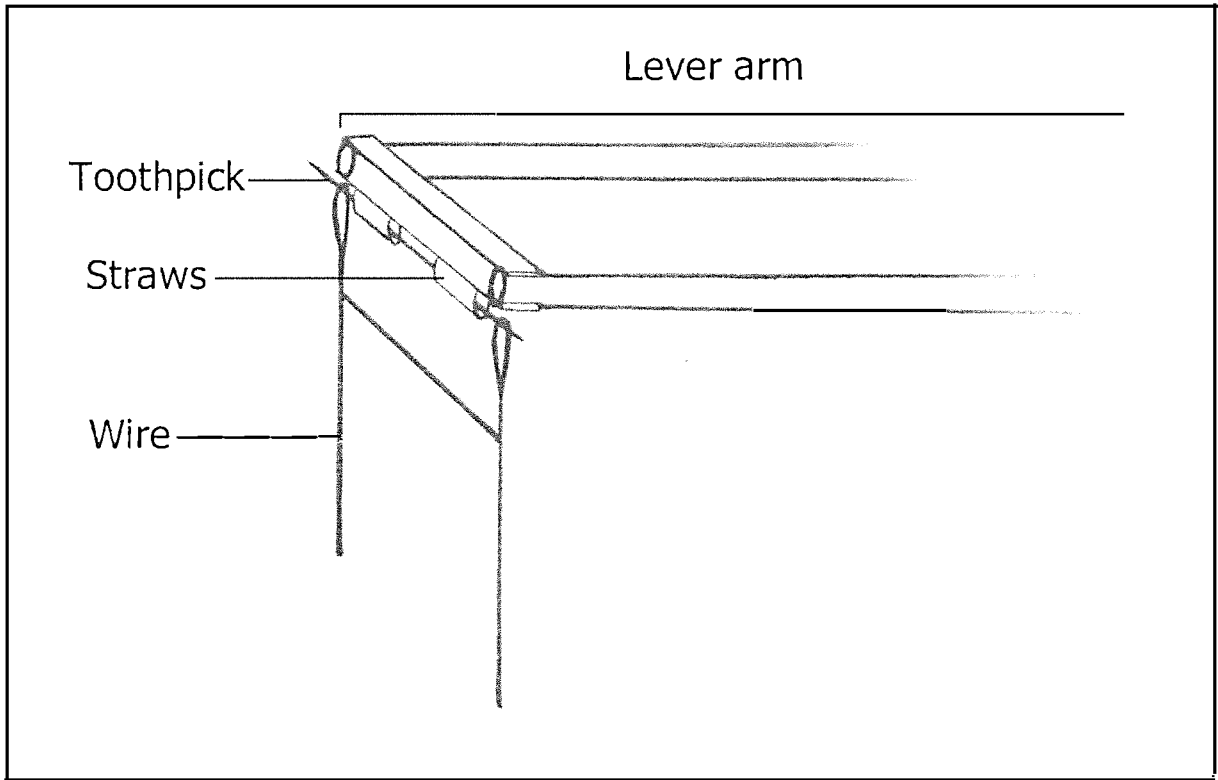

*shows wire in water*  
*shows the film in diagram*  
*KXX*

The wire formed into an "H" shaped frame so that when it was lifted from the water, a film would form between the main body of the water and the three segments of the wire whose lengths are labelled in figure 5.

Figure 5: Wire Shape and Dimensions

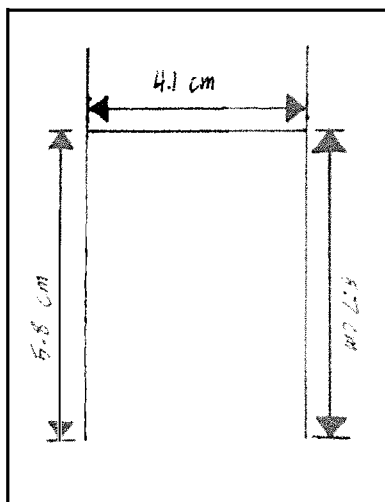

*1.8 + ?*

*a complete 3D diagram would be very helpful*  
*G*

This design was used instead of simply lifting a straight piece of wire from the surface of water in order to maintain a contact angle ( $\theta$ , figure 6) of  $0^\circ$  between the surface of the water and the normal at the point of contact between the water and the wire. Figure 6 shows the surface of the water if a single, straight piece of wire had been used while figure 7 shows the surface of the water if the frame depicted in figure 5 was used. In figures 6 and 7,  $F_\gamma$  is the magnitude of the force exerted by the surface of the water onto the wire from either side. The net force experienced by the wire is the sum of the forces exerted onto the wire by the two surfaces in contact with it and is equal to  $2F_\gamma \cos\theta$  [down]. When the force of surface tension is measured, it is the net force that is measured. However, in figure 6, the contact angle is unknown therefore  $F_\gamma$  cannot be determined. However, the frame shown in figure 7 maintains a contact angle of  $0^\circ$ . Therefore, the net force is equal to  $2F_\gamma$ , this allows  $F_\gamma$  to be calculated from the measured force.

of a ce  
G

✓  
C

Figure 6: Water-wire Cross Section Without Frame

Figure 7: Water-wire Cross Section With Frame

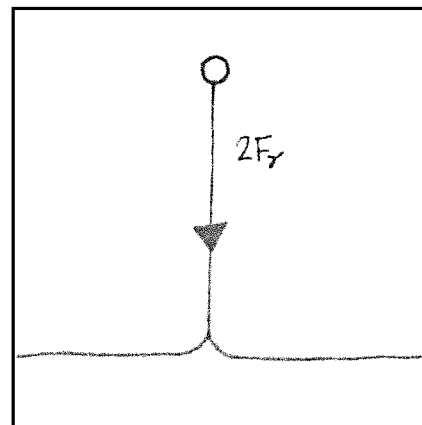
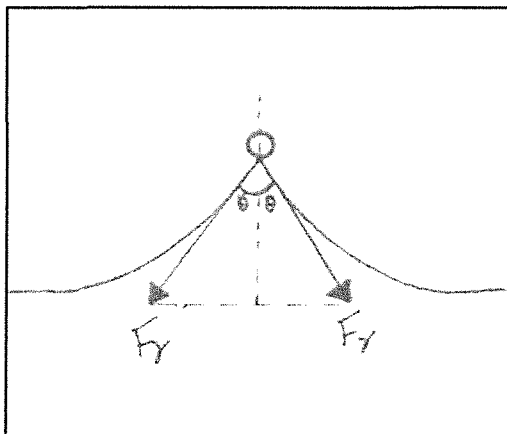

### Method

After setting up as described in the previous section, the force required to extend the surface of the water was measured by adding rice to the basket until the wire lifted off the surface of the water completely. The temperature of the water was read off the thermometer immediately after the wire lifted from the surface and was recorded. The contents of both ends of the balance were removed and their masses were recorded.

It should be noted that although a film forms due to adhesive forces between the water and all three segments of the wire frame, only the force exerted by the water onto the horizontal segment is measured because only the net vertical force is measured. Therefore, only the length ( $L$ ) of the horizontal segment was measured and used to calculate the surface tension ( $\gamma = F/2L$ ). The legs

why  
"basket"  
ends?

lets off  
diff: out  
to  
joints  
exact

of the wire frame do not contribute to the length because the force exerted by the water onto the legs is completely horizontal (figure 8).

$\Sigma F = 0$

The surface tension was then calculated as shown in the following section using the data gathered. This method allowed for small quantities of force to be measured more precisely than a spring scale would because it is not subject to human errors such as the shaking of a hand. Furthermore, by using sufficiently small weights, an acceptable level of precision can be achieved.

To investigate the relationship between temperature and surface tension, measurements for surface tension were taken at frequent but irregular intervals at temperatures ranging from 3°C to 73°C. For temperatures above 20°C, the water was heated to near boiling using a hot plate and this process was repeated as the water cooled to near room temperature. For temperatures below 20°C, the water was cooled to near freezing using ice cubes and the same was done as the water warmed up to approaching room temperature. The water was stirred between each trial to ensure that the temperature was as even as possible throughout the bulk and surface of the water. This is so that the temperature measured by the thermometer would more accurately represent the actual temperature of the surface from which the wire was lifted.

low meniscus

Figure 8: Forces Acting on the Wire

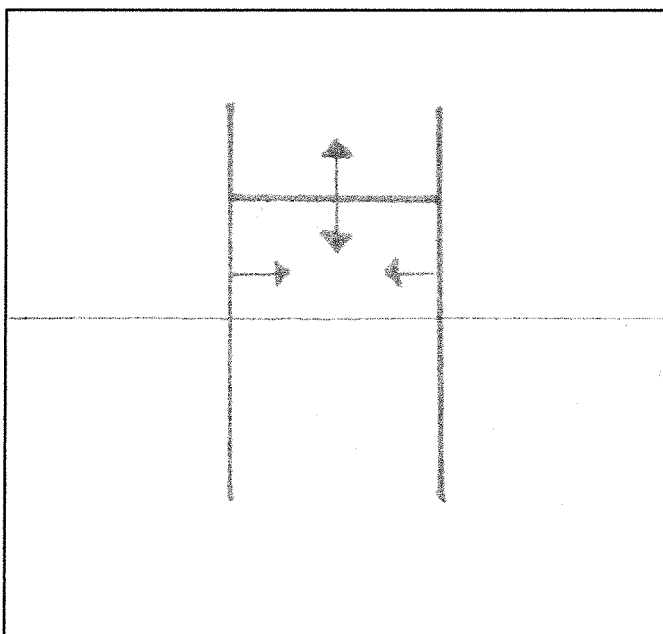

( U shape )  
← Point of water shown ...

## Data Collection

Presented here is a sample of the data collected. For the full raw data table, see appendix A.

Table 2: Sample Raw Data

| Water temperature ( $\pm 0.5^\circ\text{C}$ ) | Mass of wire end ( $\pm 0.01\text{g}$ ) | Mass of rice end ( $\pm 0.025\text{g}$ ) |
|---|---|--|
| 3.0   | 3.67                                    | 4.18                                     |
| 8.0   | 3.68                                    | 4.19                                     |
| 13.0  | 3.71                                    | 4.22                                     |
| 15.0  | 3.77                                    | 4.27                                     |
| 23.0  | 3.68                                    | 4.22                                     |
| 29.0  | 3.68                                    | 4.16                                     |
| 34.5  | 3.68                                    | 4.08                                     |
| 38.0  | 3.68                                    | 4.12                                     |
| 43.0  | 3.68                                    | 4.10                                     |
| 48.0  | 3.69                                    | 4.12                                     |
| 54.0  | 3.69                                    | 4.10                                     |
| 57.5  | 3.69                                    | 4.10                                     |
| 64.5  | 3.70                                    | 4.16                                     |
| 69.0  | 3.71                                    | 4.12                                     |
| 72.0  | 3.70                                    | 4.03                                     |
| 78.0  | 3.69                                    | 4.07                                     |

not consistent  
( $\approx \pm 1.1\%$ )

Why mass of wire end measured each time?  
C

Length of wire (horizontal segment) =  $(4.1 \pm 0.1)\text{cm}$

Diameter of wire =  $(1.02 \pm 0.005)\text{mm}$

Length of wire legs = 5.8 and  $(5.7 \pm 0.1)\text{cm}$

measured with?  $\pm$  inconsistent  
C  
F

G  
use of brackets

## Qualitative Observations

- Wire was slightly bent with some scratches
- The wire lifted water up (extending surface) slightly. However, more rice was necessary to completely lift it off surface, at which point a film formed briefly before breaking.
  - In theory, the wire should remain on the surface of the water until  $F_y$  was reached, at which point the wire should lift from the surface, forming a film which will not break as long as frame is in place
- Water droplets clung to the wire after the wire was lifted. This explains why mass of wire end varied between trials even though no changes were made to it.
- Rice pieces varied in size therefore the average mass of rice (0.025 g) was used for the uncertainties.
- When rice was added, the balance bobbed up and down several times before coming to rest. Sometimes it would not lift the wire initially but would lift after several oscillations.

I see!  
- part of calculations?  
- if so, how?  
- significant?

any data



## Data processing

The surface tension was determined by first determining the force of surface tension. As seen in figure 9,

$$F_Y + m_W g = F_B + m_R g$$

$$F_Y = F_B + m_R g - m_W g$$

because both arms of the balance are the same length.  $F_Y$  is the force of surface tension,  $m_W$  is the mass of the wire end of the balance,  $m_R$  is the mass of the rice end of the balance, and  $g$  is the strength of earth's gravitational field. The mass of any water lifted by the wire was considered negligible.

*any attempt to approximate its value*

Figure 9: Forces Acting on Balance

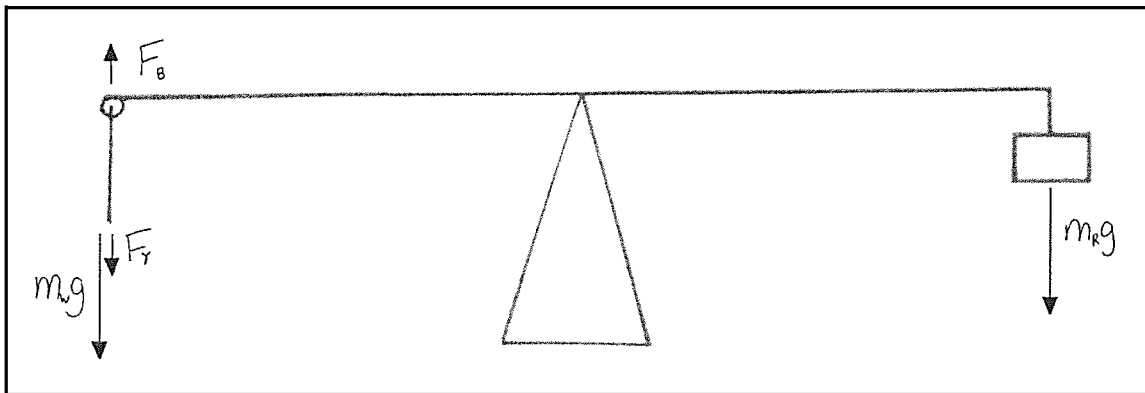

The force of buoyancy is equal to the weight of the water displaced, in this case, by the legs of wire frame. (Nave, 2014). It is assumed that the legs remain fully submerged until  $F_Y$  is reached and any water displaced by the horizontal segment of the frame is considered to be negligible. Therefore,

$$F_Y = \rho g V + m_R g - m_W g$$

$$F_Y = g(\rho V + m_R - m_W)$$

*use a direct*

Where  $\rho$  is the density of water and  $V$  is the volume of the submerged wire.

The wire was assumed to be perfectly cylindrical so the total volume was calculated using

$$V = \pi r^2 (h_1 + h_2)$$

Where  $h_1$  and  $h_2$  are the lengths of the legs. So,

*but net force on legs = 0 why take lengths of legs into account ?? for buoyancy ..*

$$F_\gamma = g(\rho\pi r^2(h_1 + h_2) + m_R - m_W)$$

Since

values of  $g, \rho, r, h_1, +h_2, m_W$   
with  $\pm$ ?  
 $\gamma = \gamma(m_R, m_W)$

$$\gamma = \frac{F}{2L}$$

$$\gamma = \frac{g(\rho\pi r^2(h_1 + h_2) + m_R - m_W)}{2L}$$

*Handwritten note:*  
\* If  
\* how can estimate  
of calculation in error  
due to uncertainty in  
data

The surface tension was calculated using this equation. Table 3 shows a sample of the processed data. See appendix B for full data table. ✓

Table 3: Sample Data Table ✓

| Water temperature ( $\pm 0.5$ K) | Surface tension ( $\text{N m}^{-1}$ ) | Surface Tension Uncertainty ( $\pm \text{N m}^{-1}$ ) |
|----------------------------------|---------------------------------------|---|
| 276.0                            | 0.072                                 | 0.005   |
| 281.0                            | 0.072                                 | 0.005   |
| 286.0                            | • 0.072                               | 0.005   |
| 288.0                            | 0.071                                 | 0.005   |
| 296.0                            | • 0.076                               | 0.005   |
| 302.0                            | 0.069                                 | 0.005   |
| 307.5                            | 0.059                                 | 0.005   |
| 311.0                            | 0.064                                 | 0.005   |
| 316.0                            | 0.061 •                               | 0.005   |
| 321.0                            | 0.063                                 | 0.005   |
| 327.0                            | 0.060 •                               | 0.005   |
| 330.5                            | 0.060 •                               | 0.005   |
| 337.5                            | 0.067                                 | 0.005   |
| 342.0                            | 0.060                                 | 0.005   |
| 245.0                            | 0.051                                 | 0.005   |
| 351.0                            | 0.057                                 | 0.005   |

*Handwritten note:*  
This  
a sample  
of raw data  
with  $m_W$  and  $m_R$   
measured in low  
of error;

Graphing the data collected yields the following graph. A linear regression was used to represent the trend shown by the data because the model (Eötvös rule) assumes that the relationship between temperature and surface tension is linear.

Figure 10: Graph of Data on the Effect of Temperature on the Surface Tension of Water

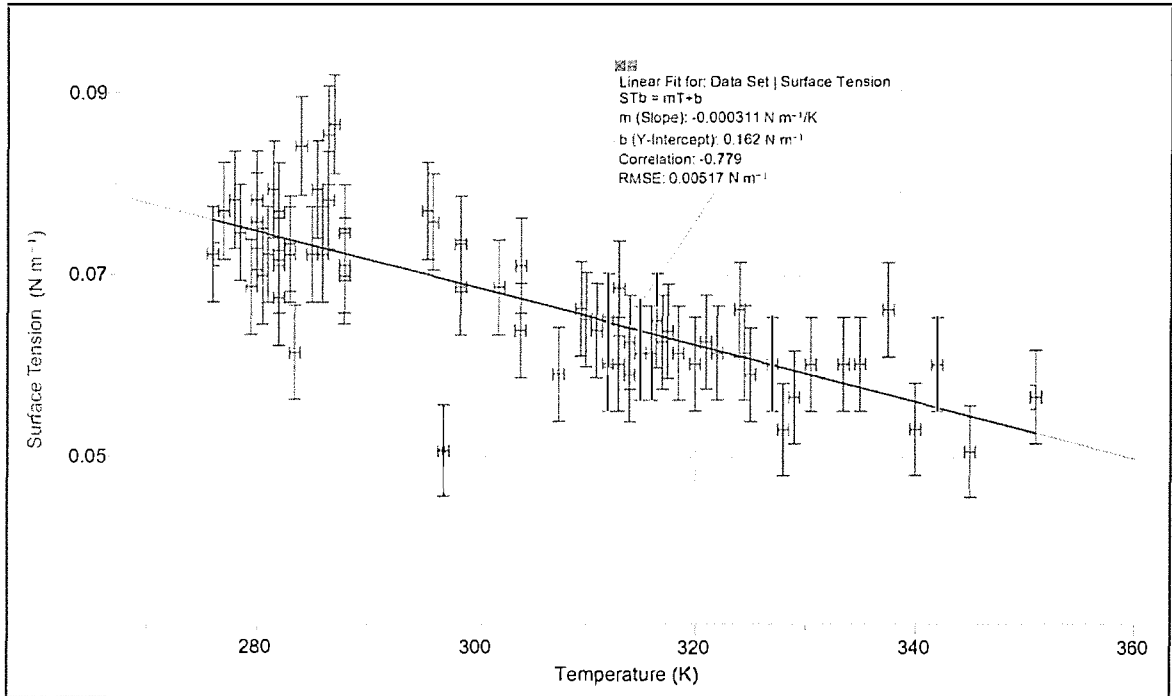

The experiment found that the relationship between temperature and surface tension can be modeled by the following equation

$$\gamma = -0.000311T + 0.162$$

Due to the nature of the data (Many data points with fairly small calculated uncertainties due to the lack of trials), no uncertainties were included for the slope and y intercept. Instead, experimental error will be assessed with different methods in the following sections.

## Discussion

### Impact of Error

To assess the degree to which the experiment was impacted by experimental error, the coefficient of determination ( $R^2$ ) and the experimental (%) error were calculated.

The coefficient of correlation ( $R$ ) given by the regression is -0.779 (figure 10). It follows that the coefficient of determination ( $R^2$ ) is 0.607.

$R^2$  gives the percentage of variance in  $y$  that is accounted for by the variance in  $x$ . (Higgins, 2005). It can also be thought of as the percentage of variance in  $y$  that is represented by the regression line. Therefore, 60.7 % of the variance in surface tension is accounted for by changes in temperature while the remaining 39.3% was caused by experimental error. Since the  $R^2$  value only takes into account the data collected and the strength of its correlation, it is a good way to evaluate the precision of an experiment. However, since it does not take into account any theories or other experimental data, it cannot be used to assess the accuracy of the experiment. From the  $R^2$  value, it is clear that the experiment lacked precision and was affected by a significant amount of random error.

The experimental error for the slope and y intercept were determined with the equation

$$\% \text{ Error} = \frac{\text{experimental result} - \text{theoretical result}}{\text{theoretical result}}$$

Using the values given by Eötvös as the theoretical results (figure 11). The experimental error for the slope was 0.822% and the experimental error for the y-intercept was -18.9%. The negative value of the error indicates that the experimental result was lower than the expected result.

Despite the significant amount of random error present in the experiment, the accuracy of the slope was preserved because the many data points collected resulted in an accurate regression line. The y-intercept, however, deviated significantly from the expected values. This can be attributed to systematic errors present in the experiment.

(a)

Figure 11: Experimental Data vs. Theoretical Models

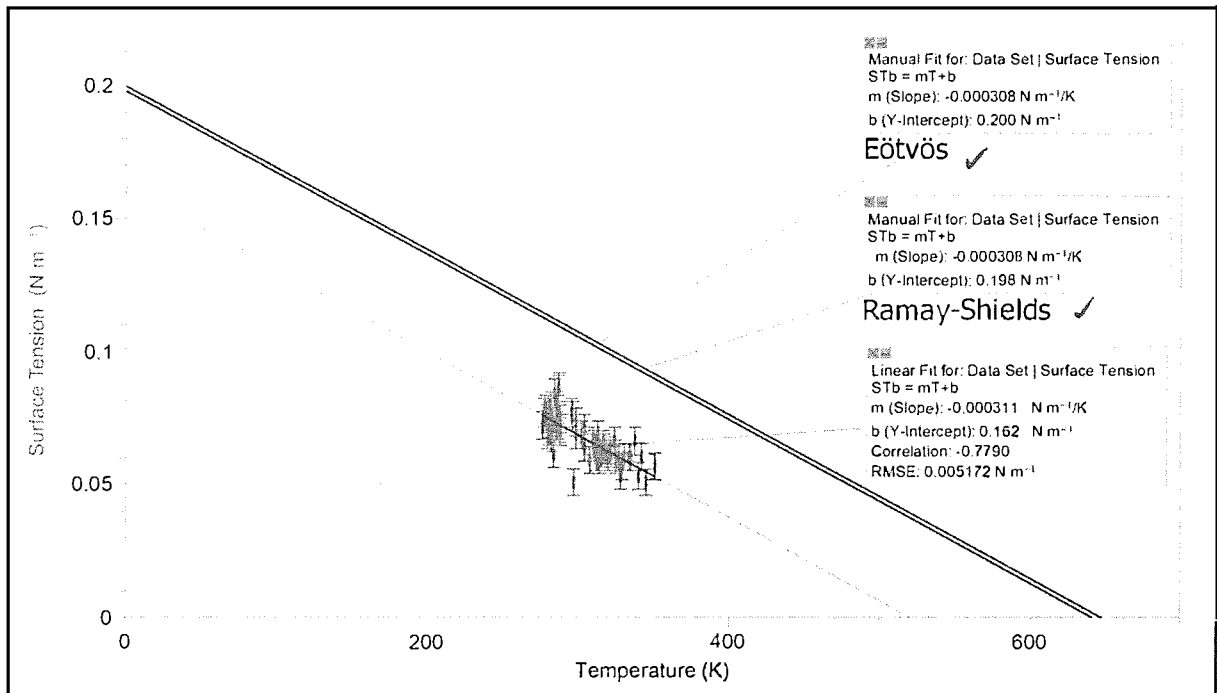

## Sources of Error and Improvements

### Solutes and Containments in Water

Dissolved substances may either increase or decrease the surface tension. Dissolved ions increase the surface tension while organic compounds usually decrease the surface tension. (Henry & Smith, 2002). Tap water contains both organic and ionic compounds; it is the abundance of each that determines whether its surface tension is greater or less than that of pure water. In this experiment, the experimental y-intercept was significantly less than the expected y-intercept, which was based on Eötvös rule for pure water. This can be explained if the water contains more organic solutes than inorganic solutes. However, since the exact composition of the water is unknown, the model cannot be altered in order to accurately reflect the conditions. Instead, water was taken from the same source in order to minimize the impact on the relationship between the independent and dependent variables (i.e. the slope). The slope of the relationship, according to Eötvös rule is given by

$$m = \frac{k}{V_m^{\frac{2}{3}}}$$

$V_m$ : molar volume  
 not a function of  
 $T$  (assumption)

Since small amounts of solute have little effect on the density of water, the impact of the impurities found in tap water on the slope of the relationship should be negligible. (Brown & ✓)

F  
 ✖  
 no attempt  
 to calculate  
 $V_m$  from data

Ford, 2009). Therefore, if the water used for each trial had the same solutes, the slope should be the same as it would be for pure water.

✓ To avoid this problem in future experiments, distilled or deionised water could be used to improve the purity of the sample.

### Temperature Measurement

The temperature measurement was not taken exactly at surface. Temperature changes more quickly at the surface. Furthermore, the measurement for temperature is not instantaneous; it takes some time for the thermometer to adjust in order to reflect the actual temperature.

Therefore, the actual temperature is lower than measured when  $T > 18^{\circ}\text{C}$  and higher than measured when  $T < 18^{\circ}\text{C}$ . This helps explain why the measured slope is slightly steeper than the expected slope.

An electronic thermometer with a small probe could be used instead to avoid the delay that occurs when the temperature is being measured. A smaller probe would also allow for the measurement to be taken closer to the surface of the water.

### External Influences

Much of the random error in this experiment can be attributed to influences from the surrounding environment, such as air flow, vibrations and even humidity. Air flow and vibrations cause the balance and the surface of the water to move, disrupting the contact between the two and thus disrupting the measurement of the surface tension. The method used to measure surface tension assumes that air behaves like an ideal gas; particularly that there are no intermolecular forces between air particles and the water. Changes in humidity as a result of evaporation, condensation and changes in air flow can affect the intermolecular forces at the air-water interface. As humidity increases, the surface tension decreases because water vapour in the air attracts water molecules at the surface of the liquid. (Pérez-Díaz, Álvarez-Valenzuela, & García-Prada, 2012). This causes the force imbalance at the surface of the water to be less than it would be if air behaved like an ideal gas. Since the humidity is not controlled it is subject to random changes throughout the experiment and thus can account for random error. Given the small forces being measured,

To reduce the impact of changes in humidity and airflow, the experiment could be performed in an isolated room with controlled air circulation and humidity. To reduce the impact of vibrations, the experiment could be performed at a time when there is little or no human activity in or near the room in which the experiment is being conducted.

any info from here at this aspect  
system of thermometer

why?  
to know using F.S. to

how big will count?

## Further Investigation

This experiment investigates the relationship between temperature and the surface tension of water. However, this is not the only factor that affects surface tension. The type and amount of dissolved solutes can also increase or decrease the surface tension. This data could be used to adjust the model to account for the presence of impurities. This would reduce or eliminate the first source of error identified above and would allow for the surface tension of impure water to be predicted.

As mentioned previously in the theories section, there exist multiple models relating the surface tension of a liquid to temperature including but not limited to those presented. Although the data collected better fits the Ramay-Shields model better than the Eötvös model (figure 11), it deviates from both too much and is too imprecise for a conclusion to be drawn regarding which model is more accurate.

## Conclusion

This experiment investigated the effect of changes in temperature on the surface of water. The results support the hypothesis which stated that if temperature increases, then the surface tension will decrease. The general trend is consistent with the theoretical models, as was the average slope. However, data points collected were consistently lower than predicted by the both the Eötvös and Ramay-Shields models. This can be attributed to impurities found in the water. Furthermore, the experiment was quite imprecise which significantly decreased the reliability of the results. Nonetheless, this experiment yielded insight regarding the relationship between surface tension and changes in temperature. However, due to the systematic errors in the experiment, the surface tension cannot be predicted reliably using the data collected.

\* What about the fact that the intercept has a discrepancy of -12.9%?

\*\* Any reason to believe that the concentration of data point at low temperatures is less reliable?

not part of  
EE



## Appendices

### Appendix A: Raw Data

| Water temperature ( $\pm 0.5^\circ\text{C}$ ) | Mass of wire end ( $\pm 0.01\text{g}$ ) | Mass of rice end ( $\pm 0.025\text{ g}$ ) |
|---|---|---|
| 3.0   | 3.67                                    | 4.18                                      |
| 4.0   | 3.67                                    | 4.22                                      |
| 5.0   | 3.67                                    | 4.23                                      |
| 5.5   | 3.67                                    | 4.20                                      |
| 6.5   | 3.67                                    | 4.15                                      |
| 7.0   | 3.67                                    | 4.23                                      |
| 7.5   | 3.67                                    | 4.16                                      |
| 7.0   | 3.67                                    | 4.21                                      |
| 8.0   | 3.68                                    | 4.19                                      |
| 8.0   | 3.68                                    | 4.19                                      |
| 9.0   | 3.74                                    | 4.24                                      |
| 8.5   | 3.73                                    | 4.30                                      |
| 9.0   | 3.72                                    | 4.27                                      |
| 9.0   | 3.73                                    | 4.20                                      |
| 10.0  | 3.72                                    | 4.23                                      |
| 10.0  | 3.72                                    | 4.24                                      |
| 10.5  | 3.71                                    | 4.13                                      |
| 11.0  | 3.72                                    | 4.33                                      |
| 12.0  | 3.71                                    | 4.22                                      |
| 12.5  | 3.71                                    | 4.28                                      |
| 13.0  | 3.71                                    | 4.22                                      |
| 13.5  | 3.71                                    | 4.33                                      |
| 13.5  | 3.72                                    | 4.28                                      |
| 14.0  | 3.97                                    | 4.60                                      |
| 15.0  | 3.83                                    | 4.36                                      |
| 15.0  | 3.78                                    | 4.27                                      |
| 15.0  | 3.77                                    | 4.27                                      |
| 22.5  | 3.68                                    | 4.23                                      |
| 23.0  | 3.68                                    | 4.22                                      |
| 24.0  | 3.69                                    | 4.02                                      |
| 25.5  | 3.69                                    | 4.17                                      |
| 25.5  | 3.68                                    | 4.20                                      |
| 29.0  | 3.68                                    | 4.16                                      |
| 31.0  | 3.68                                    | 4.18                                      |
| 31.0  | 3.68                                    | 4.12                                      |
| 34.5  | 3.68                                    | 4.08                                      |





|      |      |      |
|------|------|------|
| 36.5 | 3.68 | 4.14 |
| 37.0 | 3.68 | 4.13 |
| 38.0 | 3.68 | 4.12 |
| 38.0 | 3.68 | 4.12 |
| 39.0 | 3.69 | 4.10 |
| 39.0 | 3.68 | 4.13 |
| 40.0 | 3.69 | 4.17 |
| 40.0 | 3.68 | 4.09 |
| 41.0 | 3.69 | 4.12 |
| 41.0 | 3.68 | 4.08 |
| 42.0 | 3.68 | 4.10 |
| 43.0 | 3.68 | 4.10 |
| 43.5 | 3.68 | 4.13 |
| 44.0 | 3.68 | 4.11 |
| 44.5 | 3.69 | 4.13 |
| 45.5 | 3.68 | 4.10 |
| 47.0 | 3.69 | 4.10 |
| 48.0 | 3.69 | 4.12 |
| 49.0 | 3.69 | 4.11 |
| 51.0 | 3.68 | 4.14 |
| 51.5 | 3.69 | 4.11 |
| 52.0 | 3.69 | 4.09 |
| 54.0 | 3.69 | 4.10 |
| 55.0 | 3.69 | 4.04 |
| 56.0 | 3.69 | 4.07 |
| 57.5 | 3.69 | 4.10 |
| 60.5 | 3.69 | 4.10 |
| 62.0 | 3.69 | 4.10 |
| 64.5 | 3.70 | 4.16 |
| 67.0 | 3.70 | 4.05 |
| 69.0 | 3.71 | 4.12 |
| 72.0 | 3.70 | 4.03 |
| 78.0 | 3.69 | 4.07 |



## Appendix B: Processed Data

| Water temperature ( $\pm 0.5^\circ\text{C}$ ) | Surface tension ( $\text{N m}^{-1}$ ) | Surface Tension Uncertainty ( $\pm\text{N m}^{-1}$ ) |
|---|---------------------------------------|--|
| 276.0   | 0.072                                 | 0.005  |
| 277.0   | 0.077                                 | 0.005  |
| 278.0   | 0.078                                 | 0.005  |
| 278.5   | 0.075                                 | 0.005  |
| 279.5   | 0.069                                 | 0.005  |
| 280.0   | 0.078                                 | 0.005  |
| 280.5   | 0.070                                 | 0.005  |
| 280.0   | 0.076                                 | 0.005  |
| 281.0   | 0.072                                 | 0.005  |
| 281.0   | 0.072                                 | 0.005  |
| 282.0   | 0.071                                 | 0.005  |
| 281.5   | 0.079                                 | 0.005  |
| 282.0   | 0.077                                 | 0.005  |
| 282.0   | 0.067                                 | 0.005  |
| 283.0   | 0.072                                 | 0.005  |
| 283.0   | 0.073                                 | 0.005  |
| 283.5   | 0.061                                 | 0.005  |
| 284.0   | 0.084                                 | 0.005  |
| 285.0   | 0.072                                 | 0.005  |
| 285.5   | 0.079                                 | 0.005  |
| 286.0   | 0.072                                 | 0.005  |
| 286.5   | 0.085                                 | 0.005  |
| 286.5   | 0.078                                 | 0.005  |
| 287.0   | 0.087                                 | 0.005  |
| 288.0   | 0.075                                 | 0.005  |
| 288.0   | 0.070                                 | 0.005  |
| 288.0   | 0.071                                 | 0.005  |
| 295.5   | 0.077                                 | 0.005  |
| 296.0   | 0.076                                 | 0.005  |
| 297.0   | 0.051                                 | 0.005  |
| 298.5   | 0.069                                 | 0.005  |
| 298.5   | 0.073                                 | 0.005  |
| 302.0   | 0.069                                 | 0.005  |
| 304.0   | 0.071                                 | 0.005  |
| 304.0   | 0.064                                 | 0.005  |
| 307.5   | 0.059                                 | 0.005  |
| 309.5   | 0.066                                 | 0.005  |
| 310.0   | 0.065                                 | 0.005  |



|       |       |       |
|-------|-------|-------|
| 311.0 | 0.064 | 0.005 |
| 311.0 | 0.064 | 0.005 |
| 312.0 | 0.060 | 0.005 |
| 312.0 | 0.065 | 0.005 |
| 313.0 | 0.069 | 0.005 |
| 313.0 | 0.060 | 0.005 |
| 314.0 | 0.063 | 0.005 |
| 314.0 | 0.059 | 0.005 |
| 315.0 | 0.061 | 0.005 |
| 316.0 | 0.061 | 0.005 |
| 316.5 | 0.065 | 0.005 |
| 317.0 | 0.063 | 0.005 |
| 317.5 | 0.064 | 0.005 |
| 318.5 | 0.061 | 0.005 |
| 320.0 | 0.060 | 0.005 |
| 321.0 | 0.063 | 0.005 |
| 322.0 | 0.061 | 0.005 |
| 324.0 | 0.066 | 0.005 |
| 324.5 | 0.061 | 0.005 |
| 325.0 | 0.059 | 0.005 |
| 327.0 | 0.060 | 0.005 |
| 328.0 | 0.053 | 0.005 |
| 329.0 | 0.057 | 0.005 |
| 330.5 | 0.060 | 0.005 |
| 333.5 | 0.060 | 0.005 |
| 335.0 | 0.060 | 0.005 |
| 337.5 | 0.067 | 0.005 |
| 340.0 | 0.053 | 0.005 |
| 342.0 | 0.060 | 0.005 |
| 345.0 | 0.051 | 0.005 |
| 351.0 | 0.057 | 0.005 |

## Works Cited

v. 5000

- ✓ Alizadeh Osgouei, H., Parsafar, G. A., & Akbarzadeh, H. (2011). Density and temperature dependencies of liquid surface tension. *Scientific Information Database* , 30, 79-90.
- ✓ Brown, C., & Ford, M. (2009). *Higher Level Chemistry: Developed Specifically for the IB Diploma*. Oxford: Pearson.
- ✓ Chaplin, M. (2007, June 10). *Water's hydrogen bond strength*. Retrieved August 28, 2014, from arxiv.org: <http://arxiv.org/ftp/arxiv/papers/0706/0706.1355.pdf>
- ✓ Chen, F., & Smith, P. E. (2008). Theory and computer simulation of solute effects on the surface. *Phys Chem B.* , 112 (30), 8975–8984.
- ✓ Cutnell, J. D., & Johnson, K. W. (2006). *Essentials of physics*. Wiley Publishing.
- ✓ *Definition of interface liquid-gas and liquid-liquid interfaces*. (2012, March 21). Retrieved September 21, 2014, from dragon.unideb.hu: <http://dragon.unideb.hu/~kolloid/colloid/lectures/chembsc/lecture%2003.pdf>
- ✓ Freeman, S. (2007, October 18). *How water works*. Retrieved September 21, 2014, from HowStuffWorks.com: <http://science.howstuffworks.com/environmental/earth/geophysics/h2o7.htm>
- ✓ Ghosh, P. (2012, March 25). *Surface tension*. Retrieved September 21, 2014, from nptel.ac.in: <http://nptel.ac.in/courses/103103033/module2/lecture1.pdf>
- ✓ Henry, E. J., & Smith, J. E. (2002). The effect of surface-active solutes on water flow and contaminant transport in variably saturated porous media with capillary fringe effects. *Journal of Contaminant Hydrology* , 56 (3-4), 247 - 270.
- ✓ Higgins, J. (2005). *The radical statistician*.
- ✓ Hipschman, R. (1995). *Sticky water*. Retrieved September 21, 2014, from exploratorium.edu: [http://www.exploratorium.edu/ronh/bubbles/sticky\\_water.html](http://www.exploratorium.edu/ronh/bubbles/sticky_water.html)
- ✓ Lautrup, B. (2009). Surface tension. In *Physics of continuous matter* (2nd ed.). CRC Press.
- ✓ Nave, R. (2014, November 3). *Buoyancy*. Retrieved November 15, 2014, from HyperPhysics: <http://hyperphysics.phy-astr.gsu.edu/hbase/pbuoy.html>
- ✓ Pérez-Díaz, J. L., Álvarez-Valenzuela, M. A., & García-Prada, J. (2012, September 21). *The effect of the partial pressure of water vapor on the surface tension of the liquid water-air interface*. Retrieved September 21, 2014, from pubmed.gov: <http://www.ncbi.nlm.nih.gov/pubmed/22717083>

- ✓ *Surface tension*. (n.d.). Retrieved September 21, 2014, from chem.purdue.edu:  
<http://www.chem.purdue.edu/gchelp/liquids/tension.html>
- ✓ Syms, R. R., Yeatman, E. M., Bright, V. M., & Whitesides, G. M. (2003). Surface tension-powered self-assembly of microstructures -- the state-of-the-art. *Journal of Microelectromechanical Systems*, 12 (4).
- ✓ Vowell, S. (2009, March 19). *Microfluids: the effects of surface tension*. Retrieved March 18, 2014, from phys.washington.edu: [http://www.phys.washington.edu/~sharpe/486/vowell\\_f.pdf](http://www.phys.washington.edu/~sharpe/486/vowell_f.pdf)